

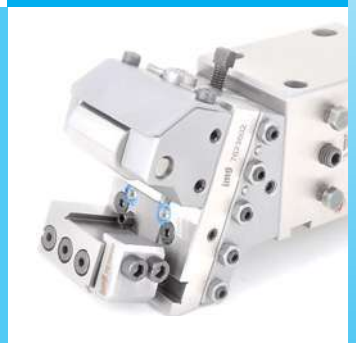

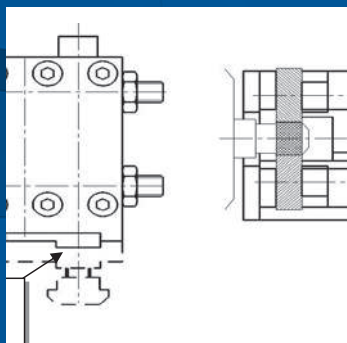

CATALOGO PORTAUTENSILI ED
APPARECCHIATURE PER MACCHINE
TORNOS
AS14-SAS16-BS20

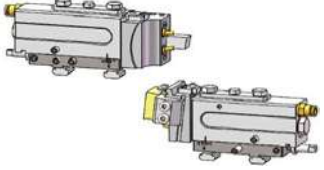

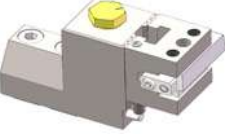
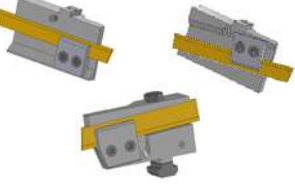
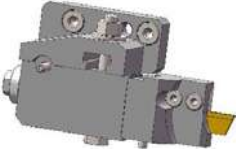

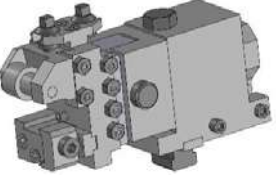
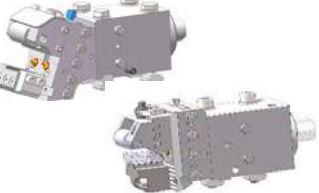
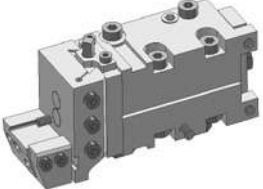

INDICE GENERALE

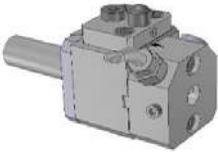
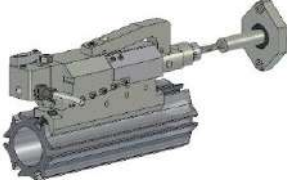
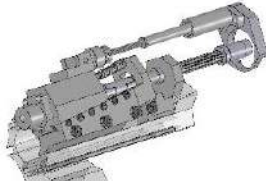
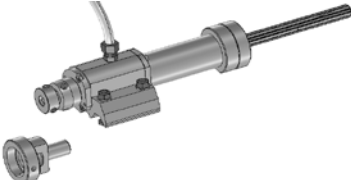
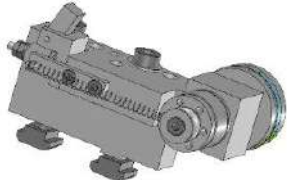
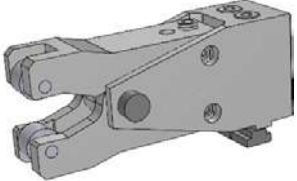
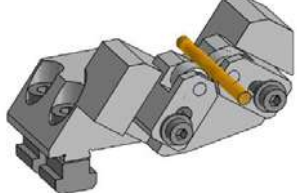
	<p>PORTA UTENSILI PRESETTABILI PRESET TOOLHOLDER</p> <p style="text-align: right;">PAG.1 PAG.1</p>
	<p>PORTA UTENSILI PER SUPPORTO CENTRALE KNEE TOOLHOLDER</p> <p style="text-align: right;">PAG.2</p>
	<p>PORTA UTENSILI DA TAGLIO PART-OFF TOOLHOLDERS</p> <p style="text-align: right;">PAG.3</p>
	<p>PORTA UTENSILI DA TAGLIO A CAMBIO RAPIDO QUICK CHANGE CUT OFF TOOLHOLDERS</p> <p style="text-align: right;">PAG.4</p>
	<p>PORTA BARENO BORING TOOLHOLDER</p> <p style="text-align: right;">PAG.5</p>
	<p>CALIBRATORE PER PICCOLI DIAMETRI SHAVING ATTACHMENT</p> <p style="text-align: right;">PAG.6</p>
	<p>CALIBRATORE SHAVING ATTACHMENT</p> <p style="text-align: right;">PAG.7 PAG.7.1</p>
	<p>PORTA UTENSILE TANGENZIALE SKIVING ATTACHMENT</p> <p style="text-align: right;">PAG.8</p>

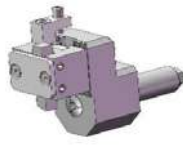
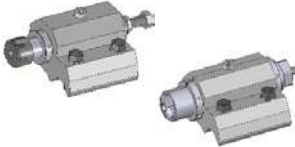
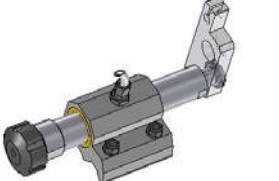
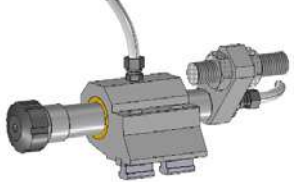

INDICE GENERALE

	TESTINA PER RECESSI A SPINTA PUSH TYPE RECESS ATTACHMENT PAG. 9 PAG. 9.1
	TESTINA PER RECESSI A RAMPA RAMP TYPE RECESS ATTACHMENT PAG. 10
	RECESSITORE ROTANTE RECESS MILLING ATTACHMENT PAG. 11
	BROCCIATORI BROCHING ATTACHMENT PAG. 12 PAG. 13
	MARCATORI MARKING ATTACH. PAG. 14 PAG. 15 PAG. 15.1
	RULLATORI E GODRONATORI BURNISHING AND KNURLING HOLDER PAG. 16
	PORTA RULLI DI SOSTEGNO ROLLER STEADIES PAG. 17

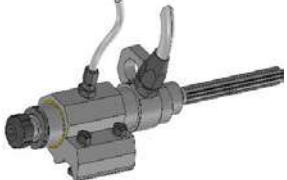
INDICE GENERALE

	<p>SUPPORTO PER TESTA A RULLARE FILETTI SUPPORT FOR THREAD ROLLING HEAD</p> <p style="text-align: right;">PAG. 18</p>
	<p>DISPOSITIVO PER RICARICA FILIERE A SCATTO DEVICE TO-RE-LOAD SELF OPENING THREADING HEAD</p> <p style="text-align: right;">PAG. 19</p>
	<p>PORTAPUNTA CON PORTAUTENSILE FRONTALE DRILL / TURNING TOOL HOLDER</p> <p style="text-align: right;">PAG. 20</p>
	<p>PORTA PUNTA FISSO DRILL HOLDER</p> <p style="text-align: right;">PAG. 21</p> <p>SAS16</p>
	<p>PORTA PUNTA FISSO INDIPENDENTE SAS16 INDEPENDENT DRILL HOLDER SAS16</p> <p style="text-align: right;">PAG. 21.1</p> <p>SAS16</p>
	<p>PORTA PUNTA INDIPENDENTE BS20 INDEPENDENT DRILL HOLDER BS20</p> <p style="text-align: right;">PAG. 21.2</p> <p>BS20</p>
	<p>GRUPPO MANDRINO CONTROROTANTE DA COMANDO INDIPENDENTE INDEPENDENT HIGH SPEED DRILLING ATTACHMENT</p> <p style="text-align: right;">PAG. 22 PAG. 22.1</p> <p>SAS16 / BS20</p>
	<p>GRUPPO MANDRINO CONTROROTANTE CON REFRIGERAZIONE INTERNA HIGH SPEED DRILLING ATTACHMENT WITH COOLANT THROUGH</p> <p style="text-align: right;">PAG. 23</p> <p>BS20</p>
	<p>GRUPPO MANDRINO CONTROROTANTE CON REFRIGERAZIONE INTERNA HIGH SPEED DRILLING ATTACHMENT WITH COOLANT THROUGH</p> <p style="text-align: right;">PAG. 24 PAG. 24.1</p> <p>SAS16</p>

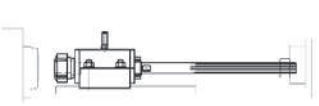
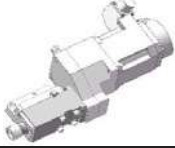
INDICE GENERALE

	GRUPPO MANDRINO CONTROROTANTE HIGH SPEED DRILLING ATTACHMENT PAG. 25 PAG. 25.1 SAS16 / BS20
	GRUPPO TESTINA A FORARE CON SERVOMOTORE PAG. 25.2 BS20
	PROLUNGHE MANDRINO SPINDLE EXTENSIONS PAG. 26
	PRESA DI MOTO DRIVING ASSEMBLY PAG. 27
	SLITTA SPECIALE RINFORZATA AS14 - SAS16 SPECIAL REINFORCED SLIDE FOR AS14 - SAS16 POS.5 PAG. 28

AS14 - SAS16 - BS20

PORTA UTENSILI PRESETTABILI con refr. interna *PRESET TOOLHOLDERS with coolant through*

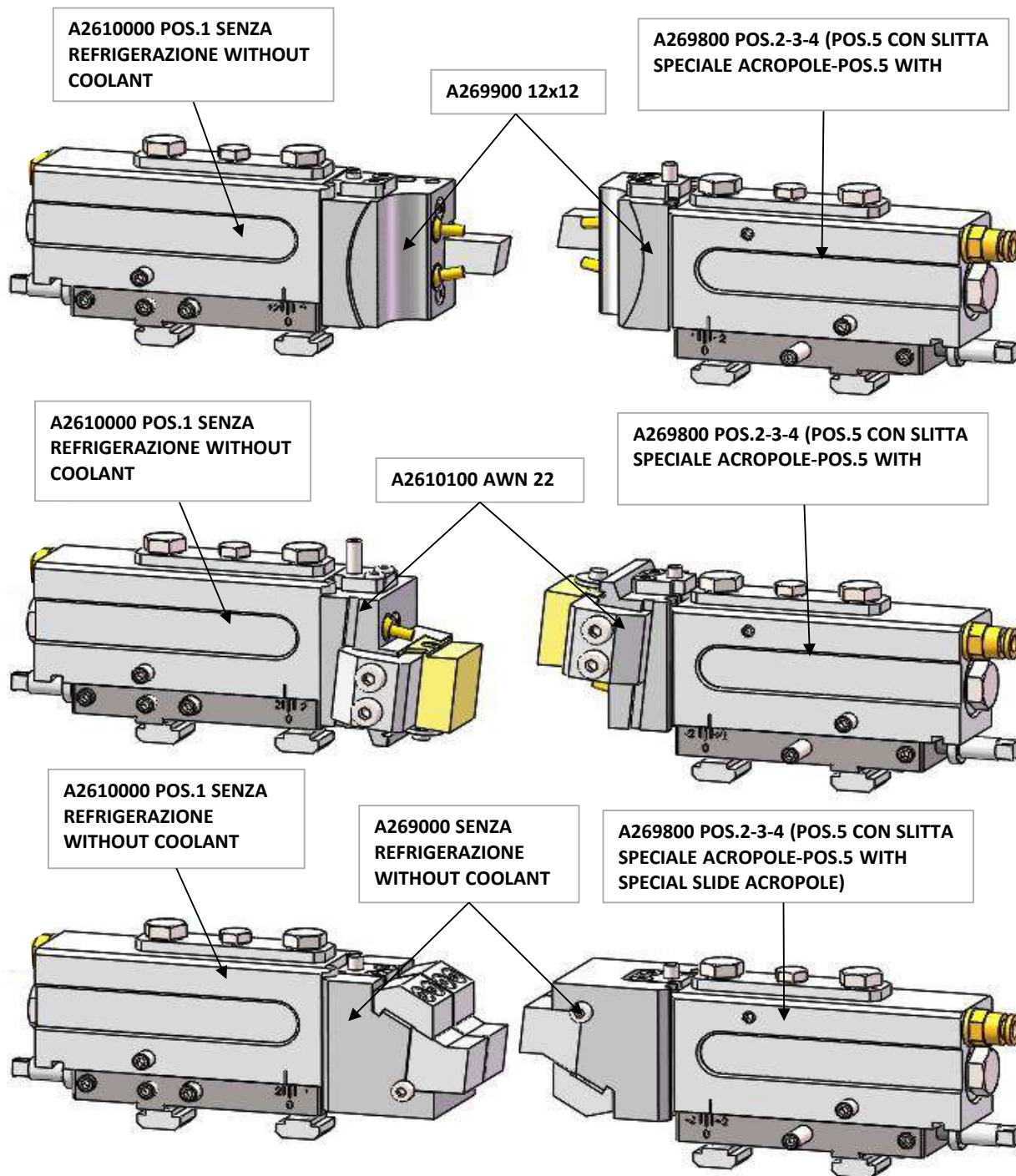

AS14 - SAS16 - BS20

PORTA UTENSILI PRISMATICI DOVETAIL TOOLHOLDERS

A484500 (STANDARD)

A484500-1 (Coolant through)

AS14 - SAS16: POS. 1-2

BS20: POS. 1-2-5-6

COD. TORNOS AS30/25

A484600 (Standard)

A484600-1 (Coolant through)

AS14 - SAS16: POS. 3-4-5

BS20: POS. 3-4-7

COD. TORNOS AS30/26

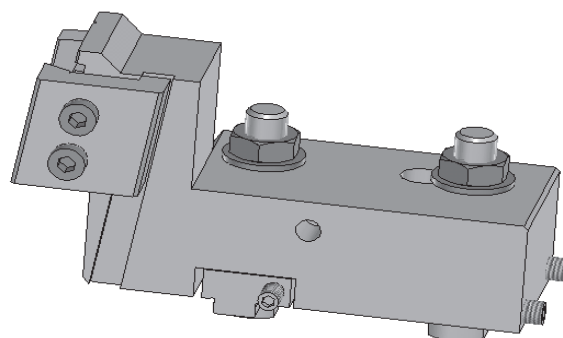
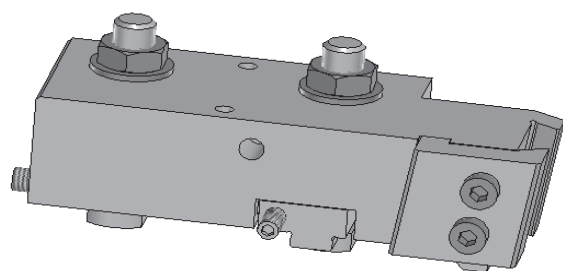

Attacco 22mm
Dovetail size 22mm

PORTA UTENSILI PER SUPPORTO CENTRALE *KNEE TOOLHOLDER*

AS14-SAS16

Versione monoblocco

Cod. 9515000

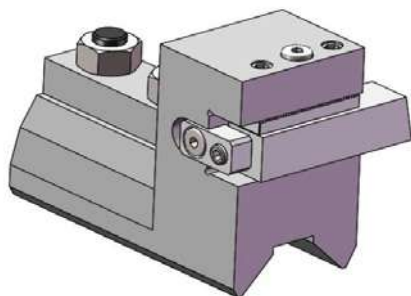

Cod. 9514900

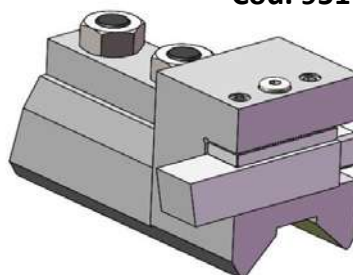

AS14-SAS16

Versione a cambio rapido reversibile

Cod. 9514600

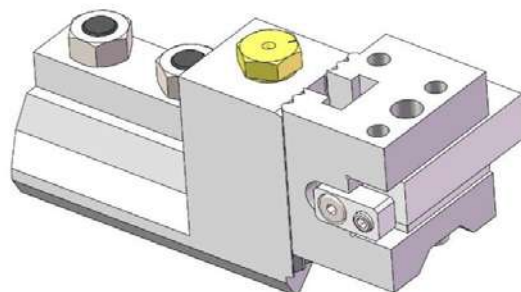

BS20

Versione a cambio rapido reversibile

Cod. 9516400

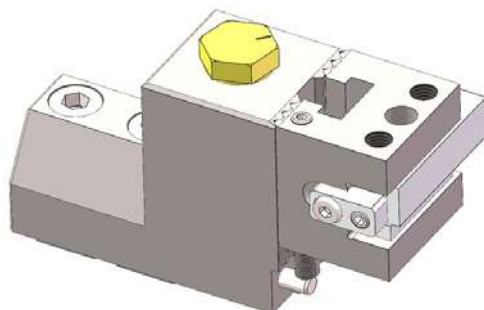

PORTALAMA - *BLADE HOLDERS*

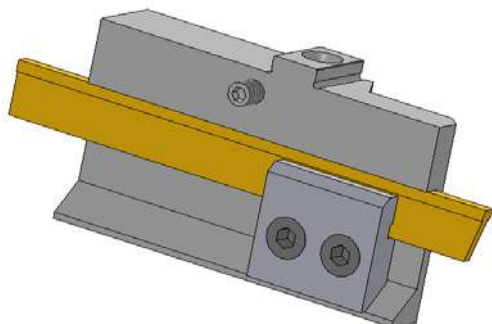

Cod. 8011800
AS14 - SAS16
Lame Empire 12mm
Uso: per Ottone / Alluminio

Montaggio su supporto
cod. AS 14789

Calibro regolazione lama
cod. 8011003 a richiesta

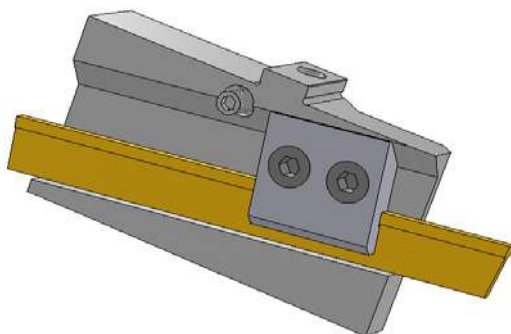

Cod. 8011000
AS14 - SAS16
Lame Empire 12mm inclinata 8°
Uso: per Acciaio

Montaggio su supporto
cod. AS 14789

Calibro regolazione lama
cod. 8011003 a richiesta

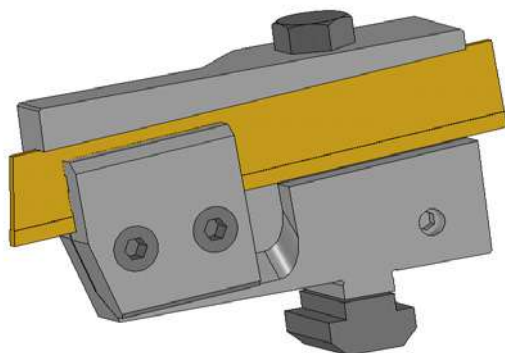

Cod. 8011200
BS20
Lame Empire 12mm inclinata 3°

Calibro di regolazione lama
cod. 8011203 a richiesta

**PORTAUTENSILE DA TAGLIO A CAMBIO RAPIDO
PER TORNOS AS14-SAS16
QUICK CHANGE CUT OFF TOOL HOLDER FOR
TORNOS AS14-SAS16**

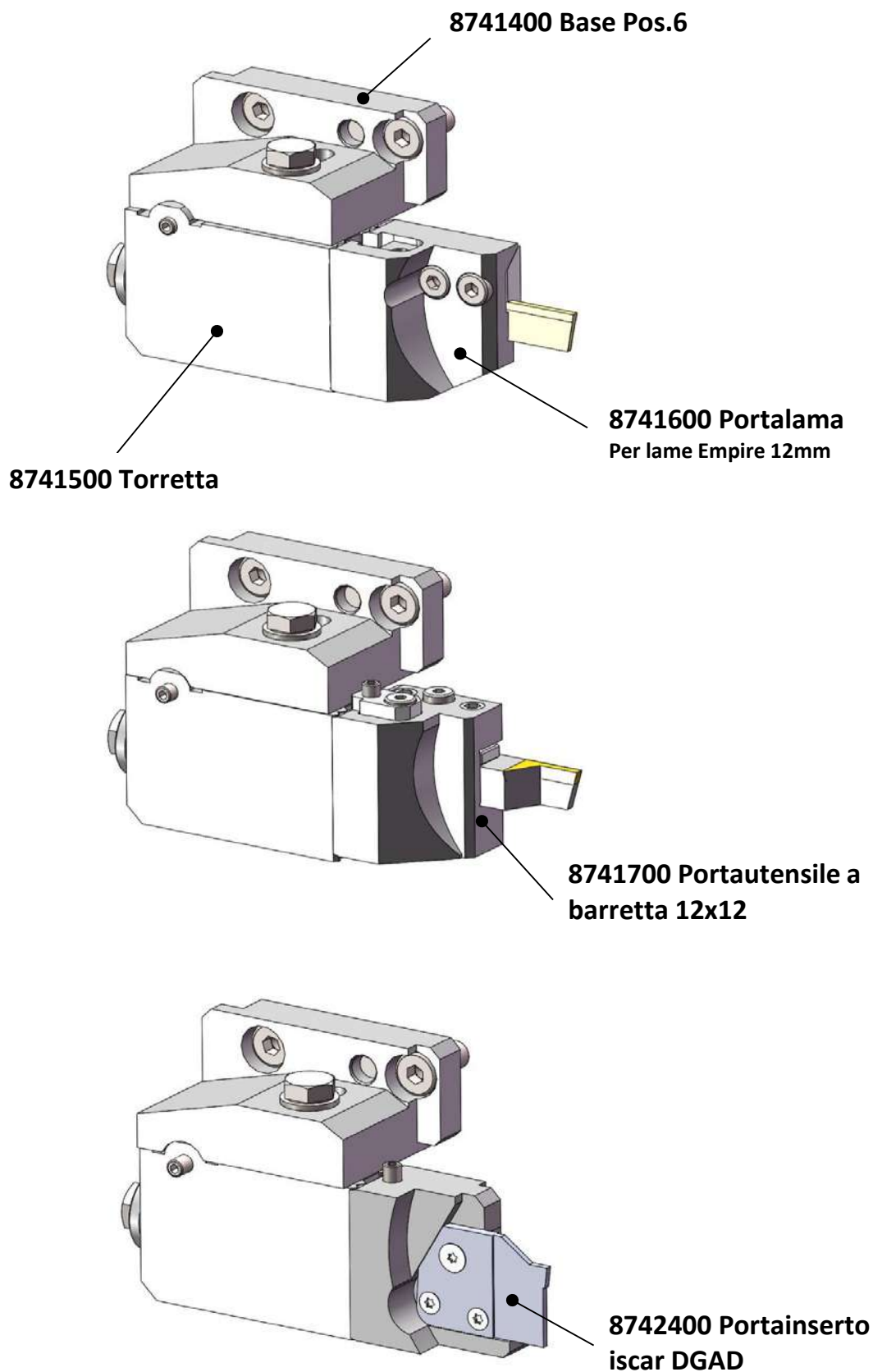

PORTABARENO MODULARE *ADJUSTABLE BORING HOLDER*

9515100

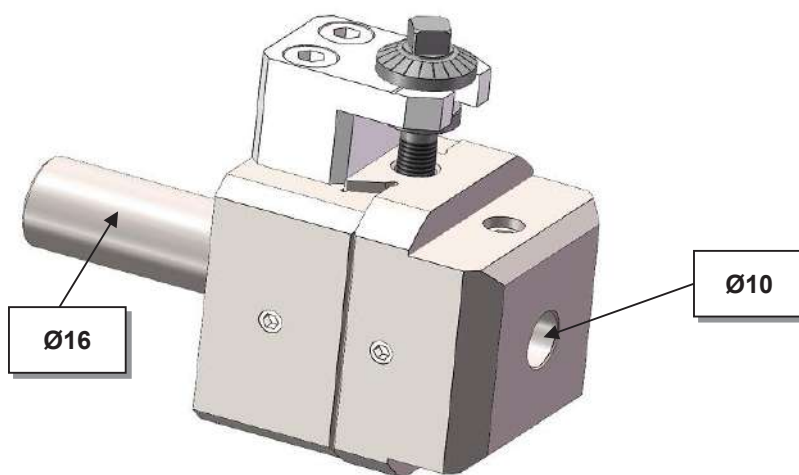

CALIBRATORE PER PICCOLI DIAMETRI SHAVING ATTACHMENT FOR SMALL PARTS

Grazie alla piccola spinta applicata al pezzo in lavorazione, questo calibratore è particolarmente indicato per diametri inferiori a 10mm

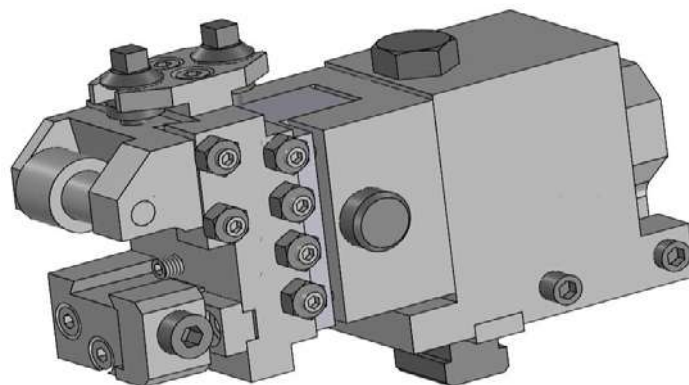

7610600

AS14 - SAS16 POS. 3: A max=7mm

AS14 - SAS16 POS. 4-5: A max=10mm

BS20 Pos. 2...7: A max=10mm

Dimensioni:

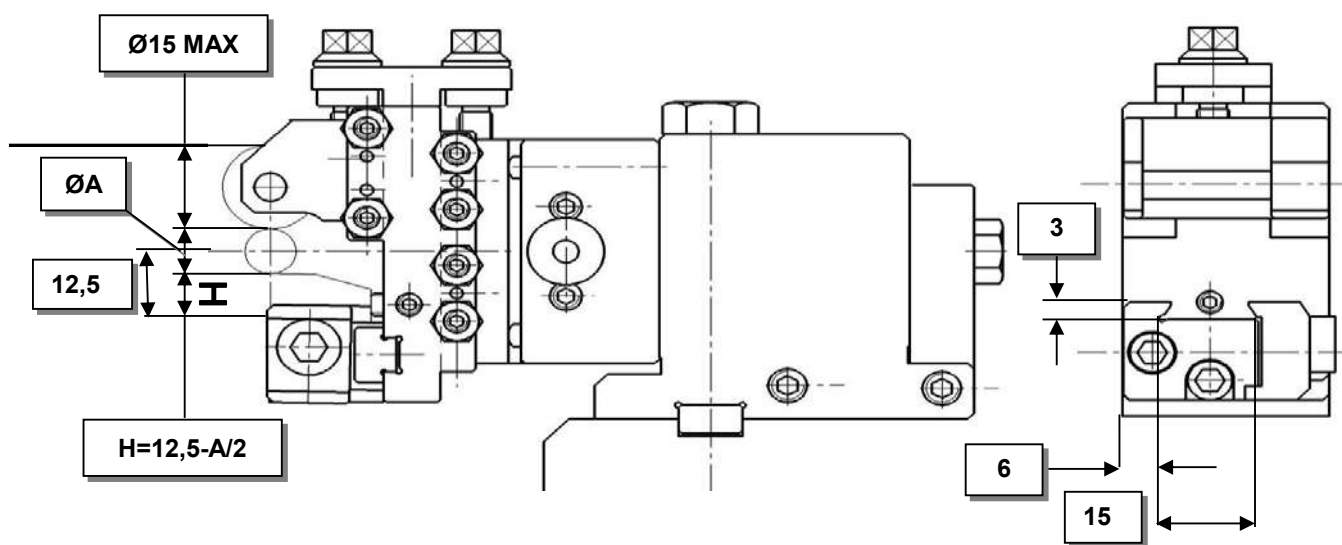

CALBRATORE INCLINATO 20° CON REFRIGERAZIONE INTERNA - INCLINED SHAVING ATTACHMENT WITH COOLANT THROUGH

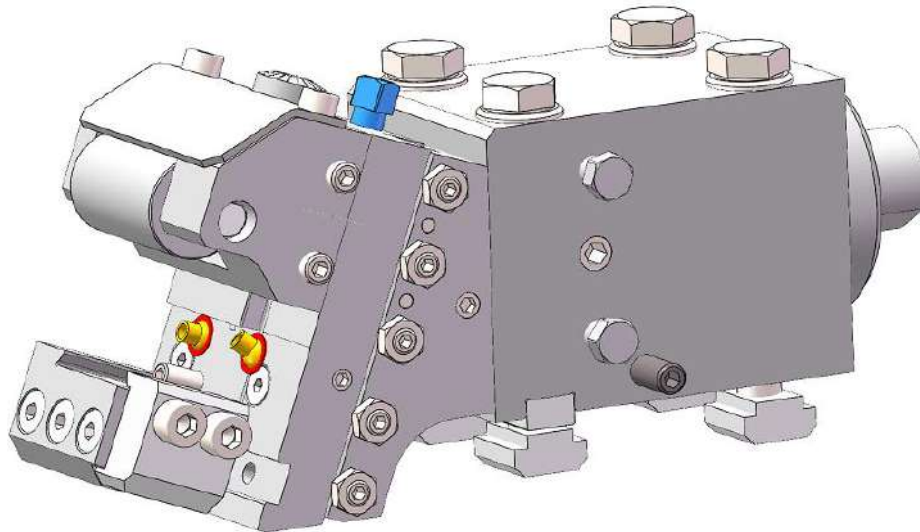

7623600

AS14 - SAS16 POS. 3: A max=10 D max=14

AS14 - SAS16 POS. 4-5: A max=16 D max=18

BS20 Pos. 3-4-7: A max=16 D max=18

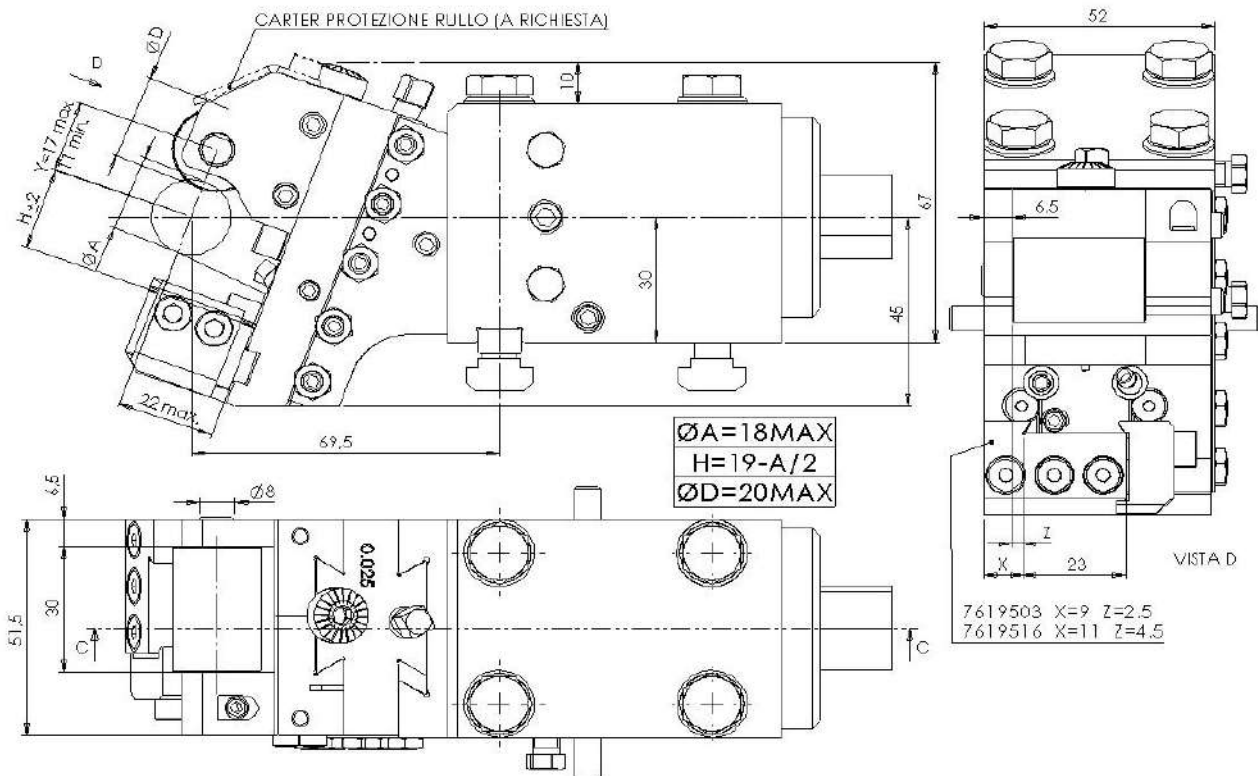

CALBRATORE CON REFRIGERAZIONE INTERNA - SHAVING ATTACHMENT WITH COOLANT THROUGH

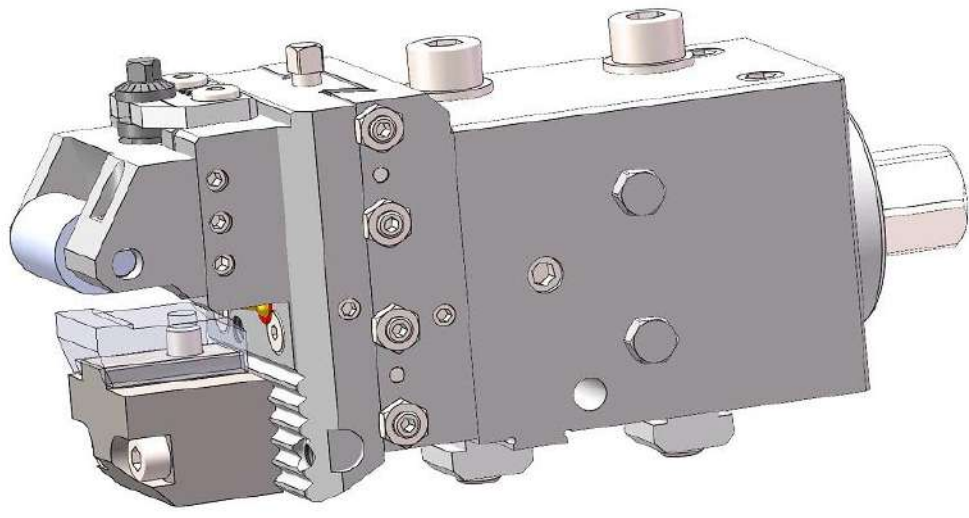

7625000
AS14 - SAS16 POS. 3-4-5

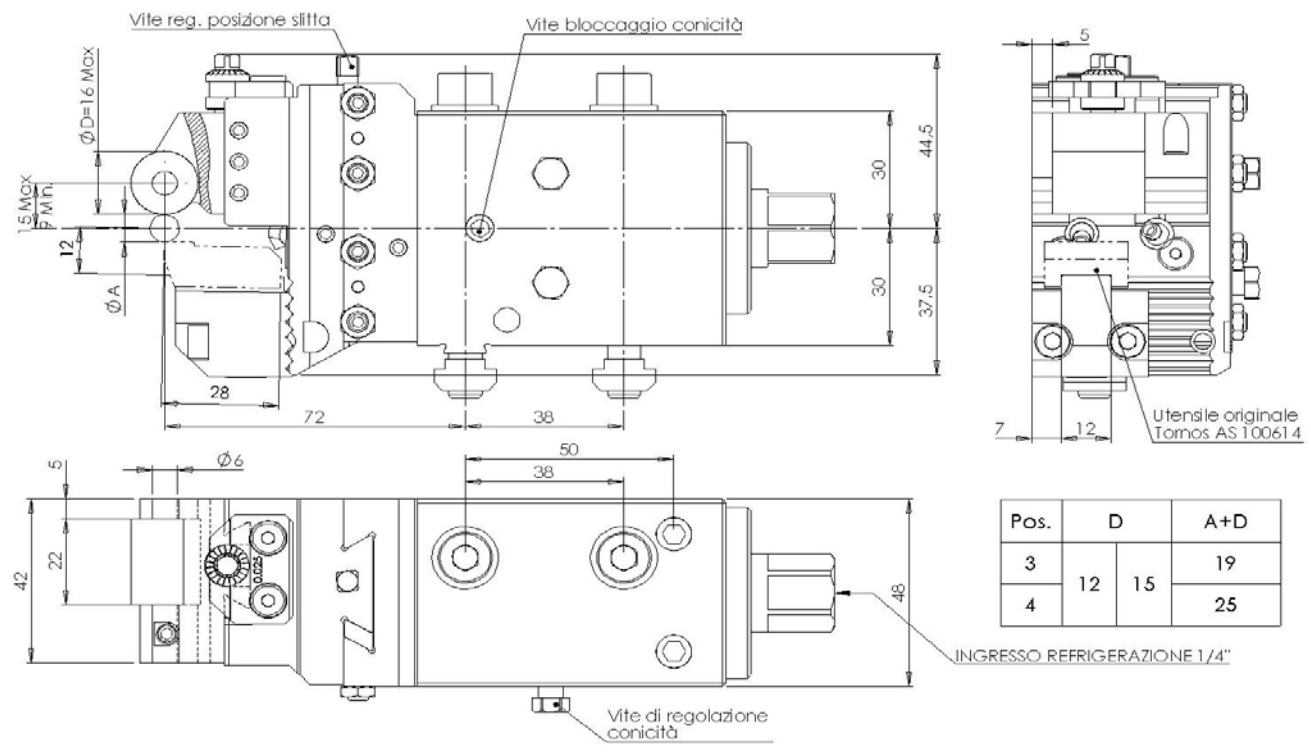

PORTAUTENSILE TANGENZIALE SKIVING TOOL HOLDER

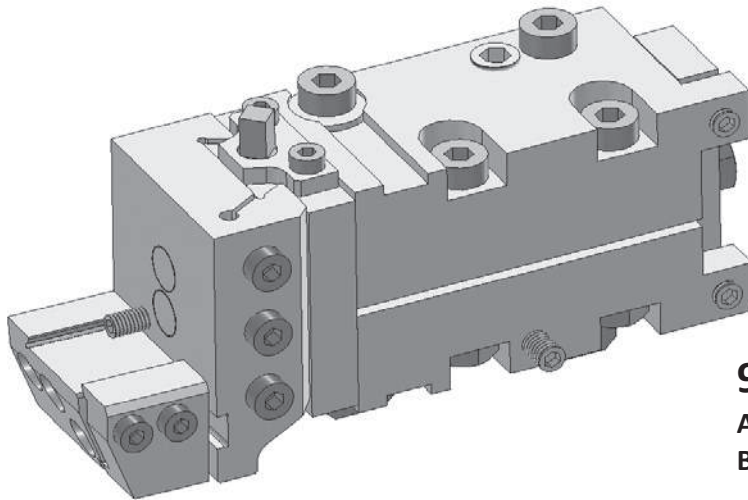

992000

AS14 - SAS16 POS. 2-3-4-5

BS20 Pos. 2-3-4-5-6-7

**CON REFRIGERAZIONE
WITH COOLANT THROUGH**

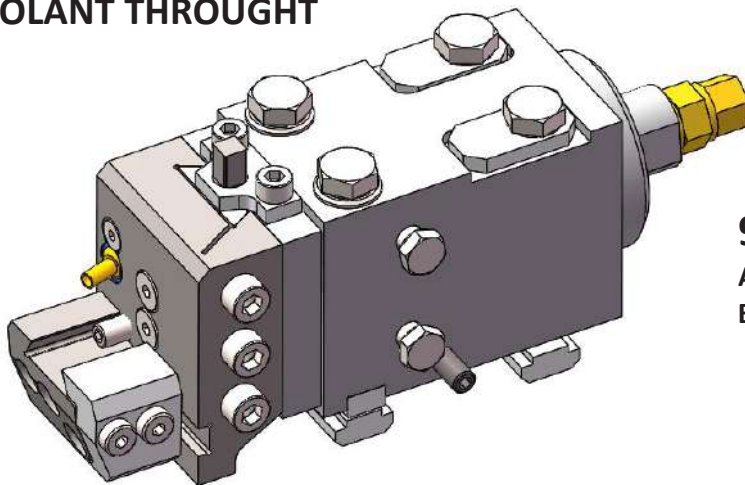

994000

AS14 - SAS16 POS. 2-3-4-5

BS20 Pos. 2-3-4-5-6-7

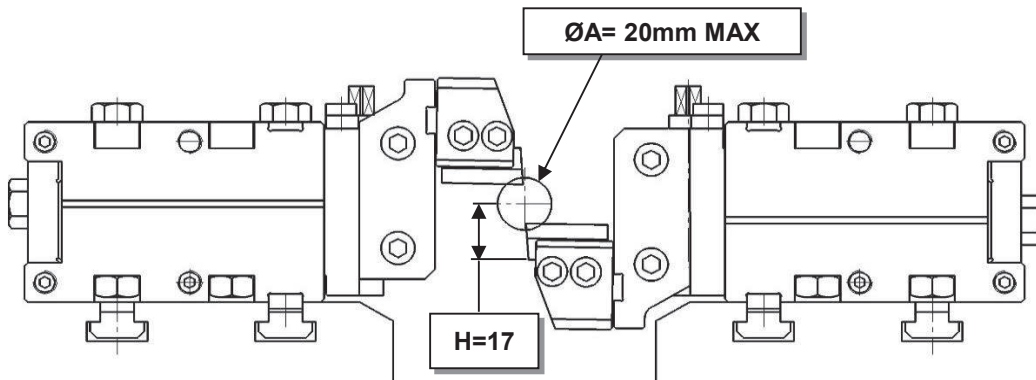

**ALTRI TIPI DI ATTACCHI
UTENSILE A RICHIESTA
OTHER DOVETAIL SIZES ON
REQUEST**

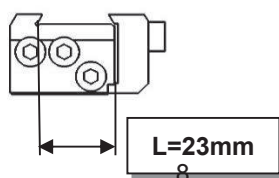

TESTINA PER RECESSI A SPINTA PUSH TYPE RECESS HEAD

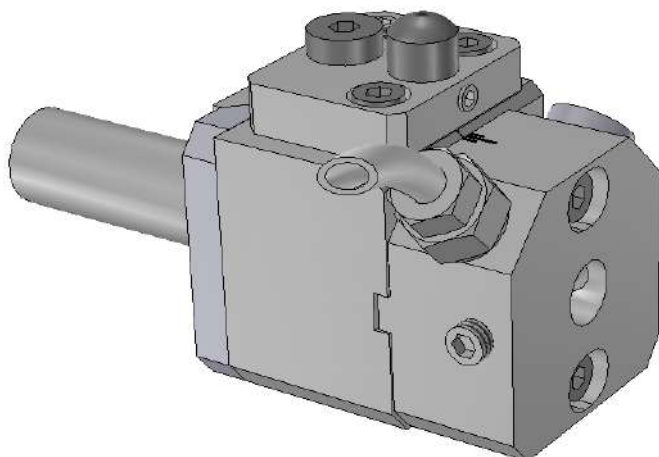

9513300

AS14 - SAS16 PS.2-3-4

BS20 POS.2-3-4-5-6-7

9515800

SPINTORE PER TORNITURE IN PASSATA a richiesta
LONGITUDINAL TURNING PUSH UNIT on request

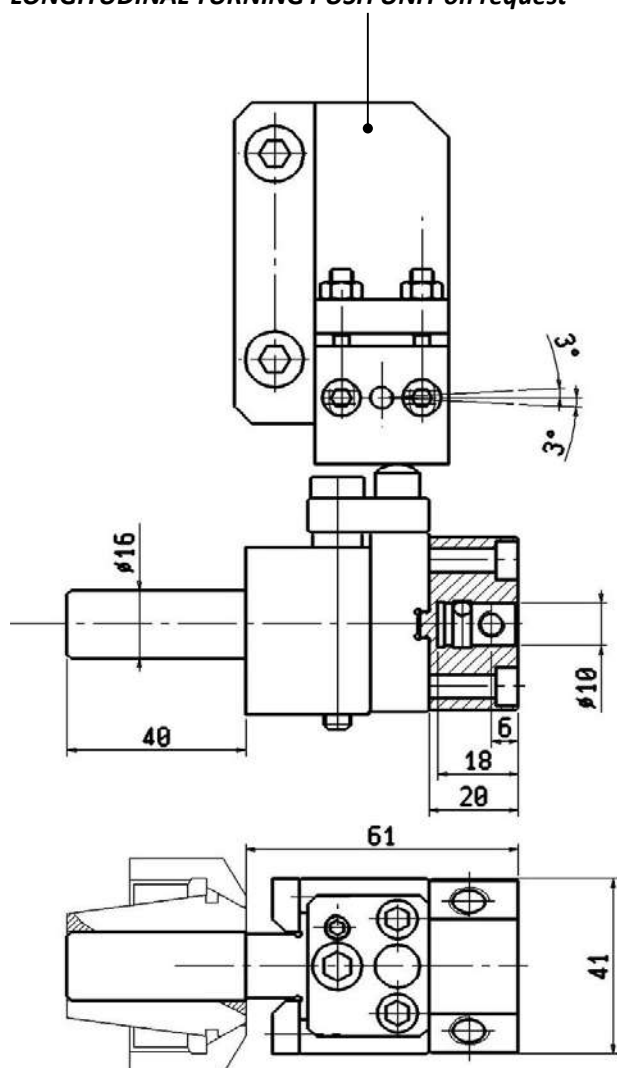

9515700

SPINTORE a richiesta
PUSH UNIT on request

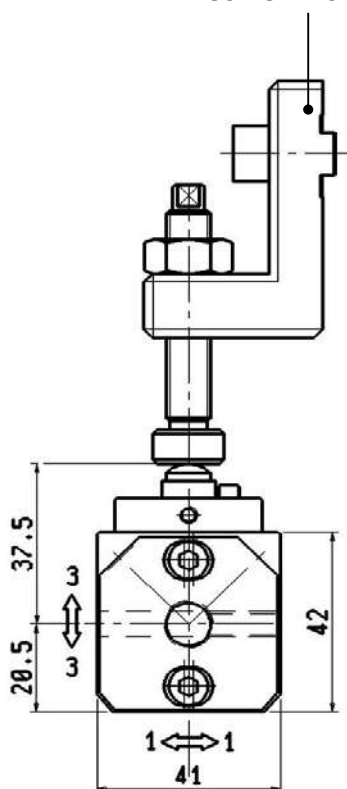

TESTINA PER RECESSI A SPINTA PUSH TYPE RECESS HEAD

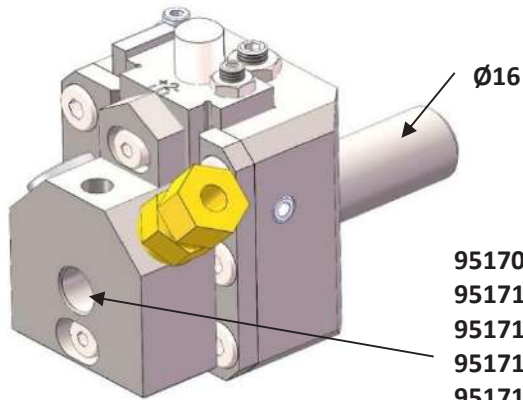

951700
BS20 POS.2-3-4-5-6-7

- 951702 Ø8
- 951715 Ø10
- 951716 Ø12
- 951717 Ø14
- 951718 Ø15
- 951719 Ø16

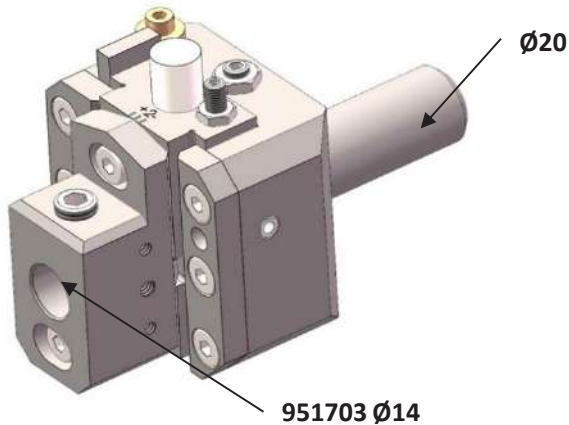

951400 (VERSIONE RINFORZATA)
BS20 POS.2-3-4-5-6-7

951703 Ø14

951580
SPINTORE PER TORNITURE IN PASSATA a richiesta
LONGITUDINAL TURNING PUSH UNIT on request

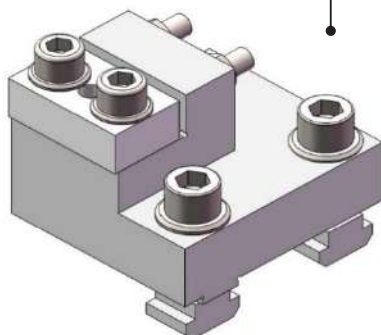

9515700
SPINTORE a richiesta
PUSH UNIT on request

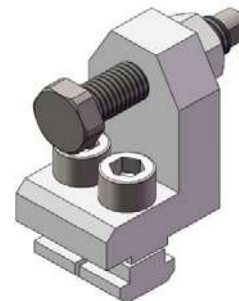

TESTINA PER RECESSI A RAMPA PER AS14-SAS16
RAMP TYPE RECESS HEAD

00811300

INCLINAZIONE RAMPA: 8°

MAX. CORSA RADIALE: 4,5mm

DIAMETRO PORTAUTENSILE:10mm

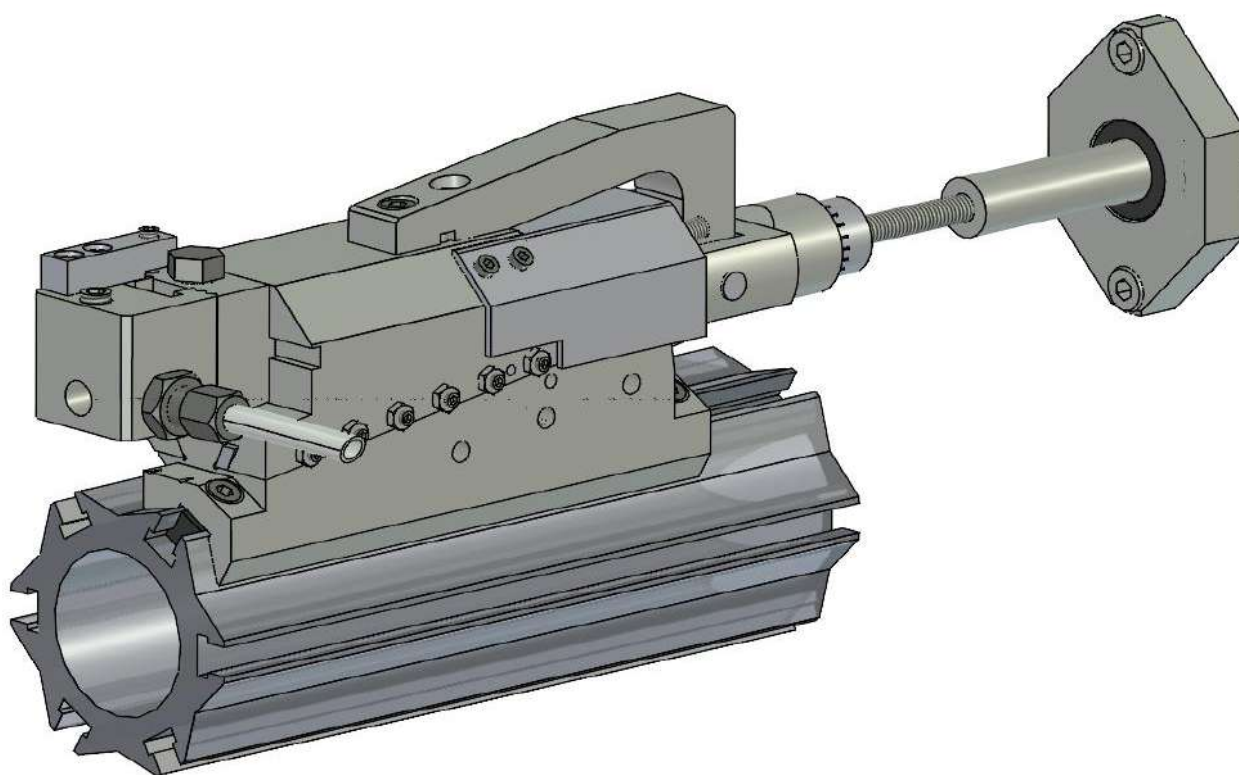

RECESSITORE ROTANTE PER AS14 - SAS16
RECESS MILLING ATTACHMENT FOR AS14-SAS16

A3112300

POS. 3 E 5

A3112300-1

POS. 4

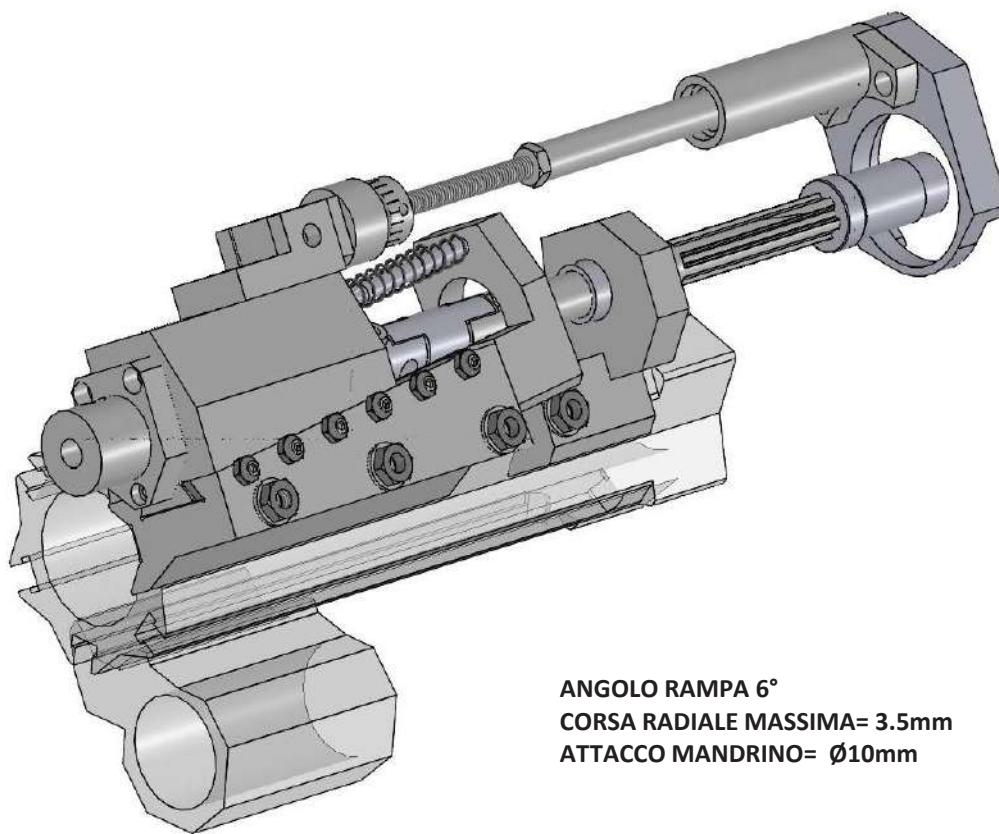

ANGOLO RAMPA 6°
CORSA RADIALE MASSIMA= 3.5mm
ATTACCO MANDRINO= Ø10mm

BROCCIATORE SINCRONO INCLINATO 1° 1° SYNCHRONOUS BROACHING ATTACHMENT

0056100

AS14 - SAS16

UN PORTABROCCIA FORNITO IN DOTAZIONE

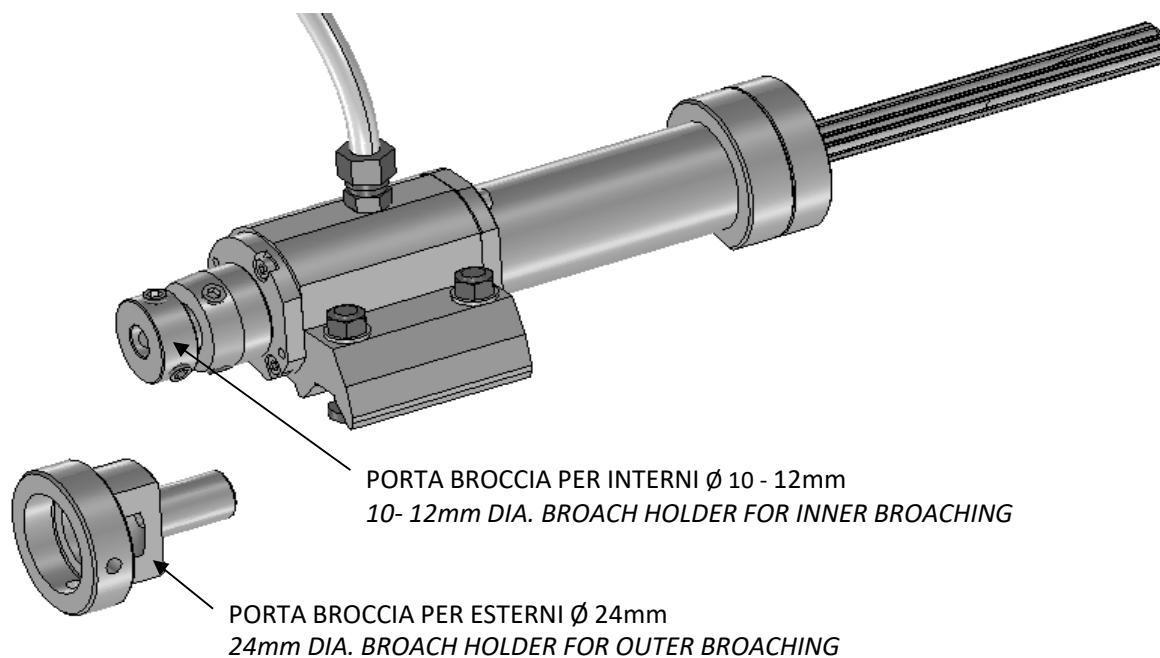

BROCCIATORE SINCRONO INCLINATO 1° 1° SYNCHRONOUS BROACHING ATTACHMENT

0055900-1

BS20

UN PORTABROCCIA FORNITO IN DOTAZIONE

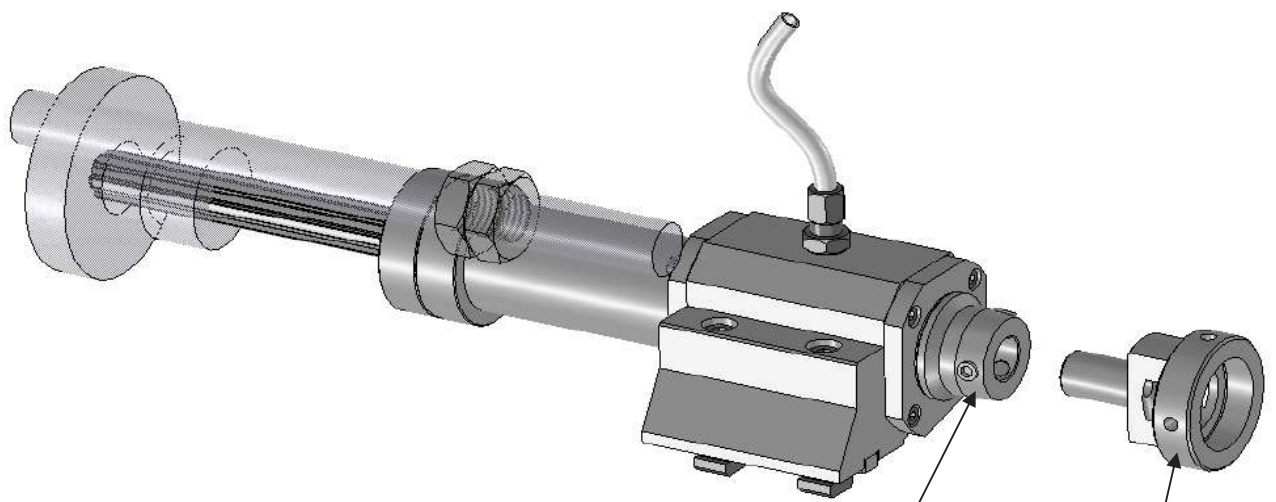

PORTA BROCCIA PER INTERNI \varnothing 12mm
12mm DIA. BROACH HOLDER FOR INNER BROACHING

PORTA BROCCIA PER ESTERNI \varnothing 38mm
38mm DIA. BROACH HOLDER FOR OUTER BROACHING

MARCATORE MARKING ATTACHMENT

7514600

AS14 - SAS16 Pos. 3-4

BS20 Pos. 2....7

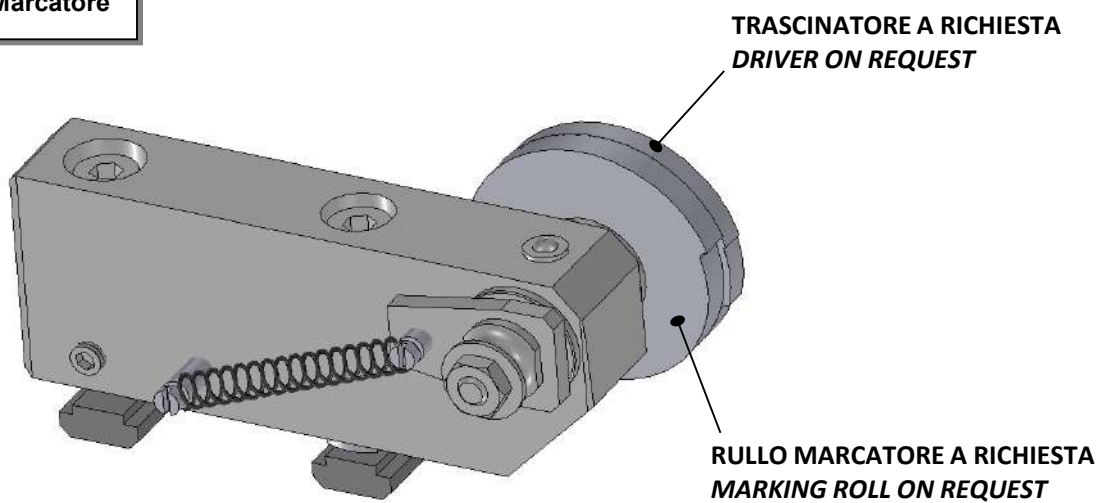
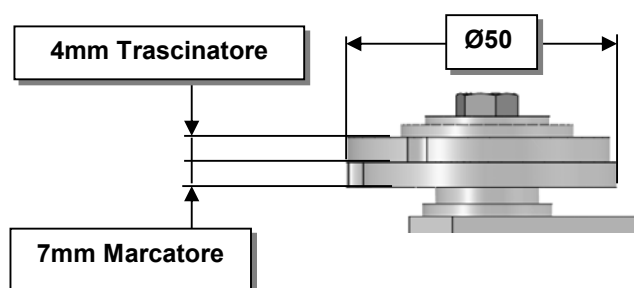

MARCATORE CON RICARICA SELF LOCKING MARKING ATTACHMENT

spintore per ricarica non incluso
reset device not included



7511100

AS14 - SAS16 Pos. 3-4
BS20 Pos. 2....7

7513800

Adattatore escluso
Adapter not included

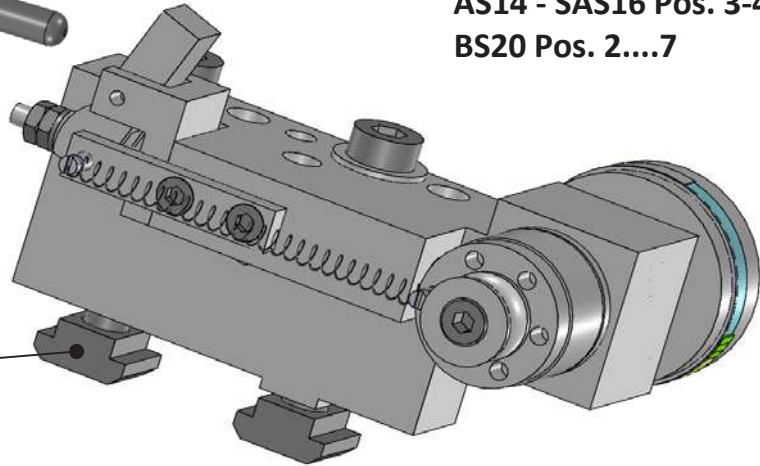

756800

Rullo con inserti intercambiabili non incluso
interchangeable inserts marking roller not included

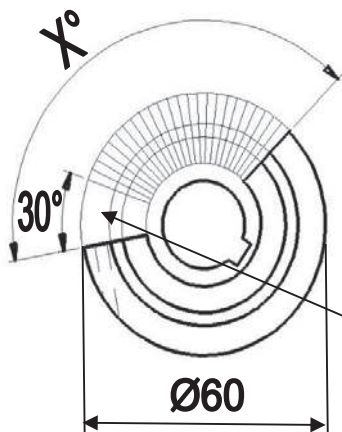
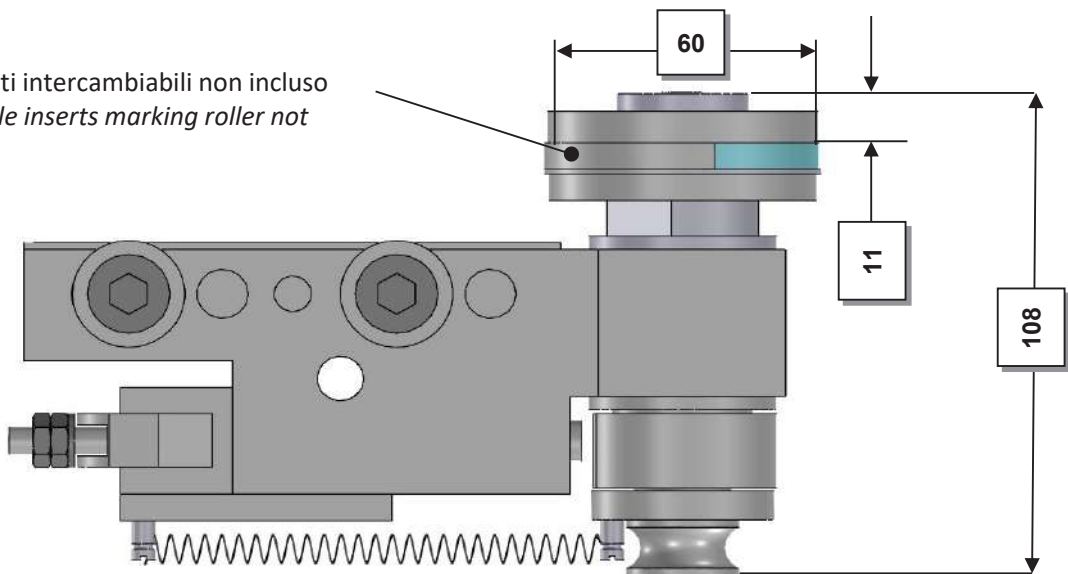

TRASCINATORE
DRIVER 755903

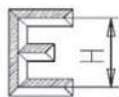

H=2	X°=145°	quantità n°29	X°=115°	quantità n°23
H=2,5	X°=145°	quantità n°29	X°=115°	quantità n°23
H=3	X°=145°	quantità n°25	X°=115°	quantità n°20
H=4	X°=145°	quantità n°18	X°=115°	quantità n°15
H=2	X°=145°	quantity n°29	X°=115°	quantity n°23
H=2,5	X°=145°	quantity n°29	X°=115°	quantity n°23
H=3	X°=145°	quantity n°25	X°=115°	quantity n°20
H=4	X°=145°	quantity n°18	X°=115°	quantity n°15

MARCATORE CON RICARICA SELF LOCKING MARKING ATTACHMENT

7511500

Rullo con caratteri intercambiabili
tipo stretto a richiesta
*Thin marking roll with interchangeable characters
on request (narrow type)*

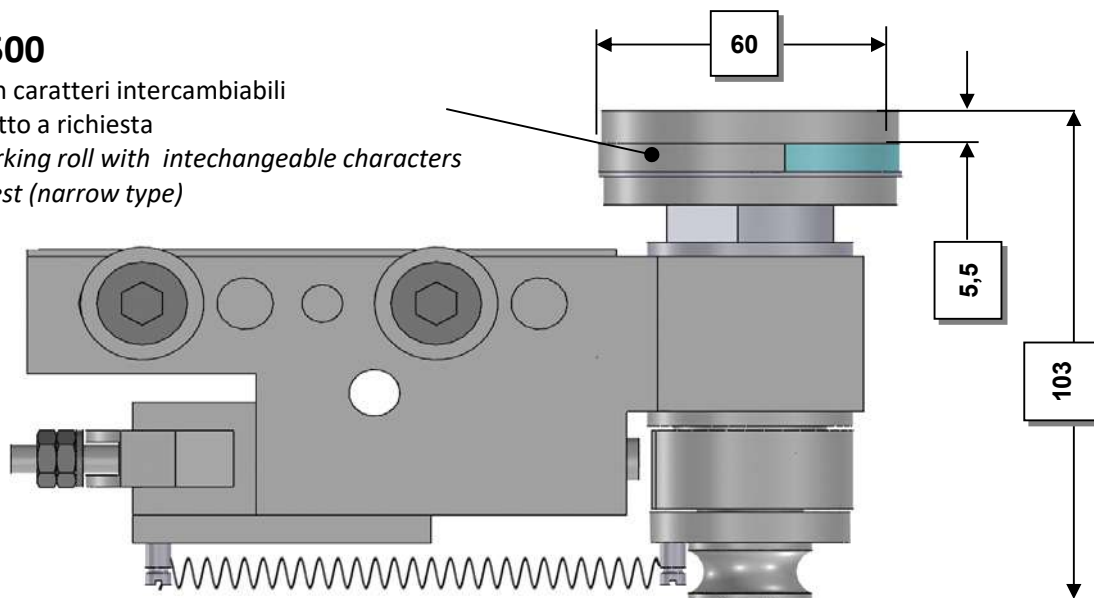

Rullo marcatore standard a richiesta
Standard marking roll on request

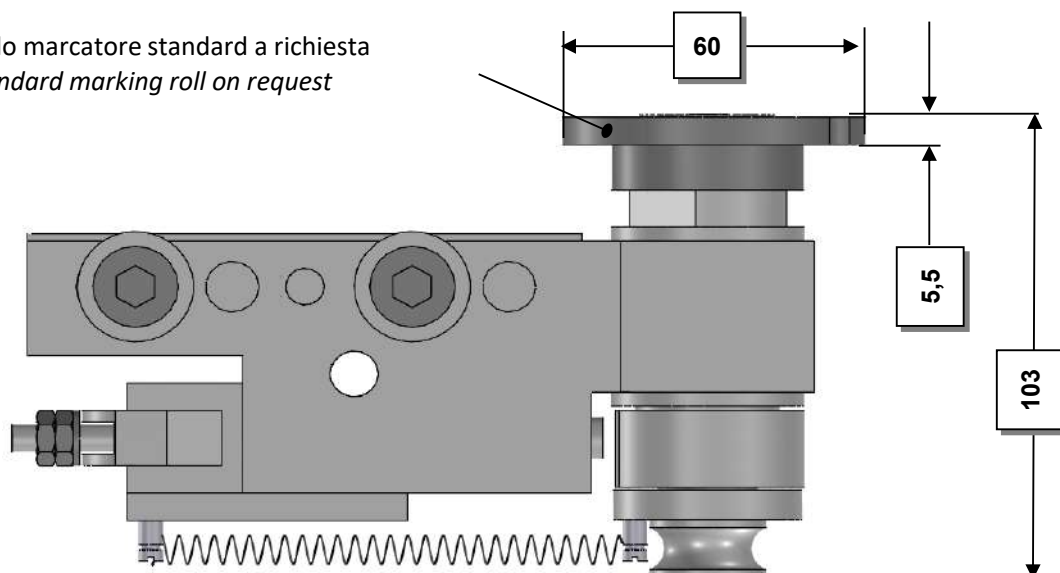

RULLATORI / GODRONATORI BURNISHING / KNURLING ATTACHMENT

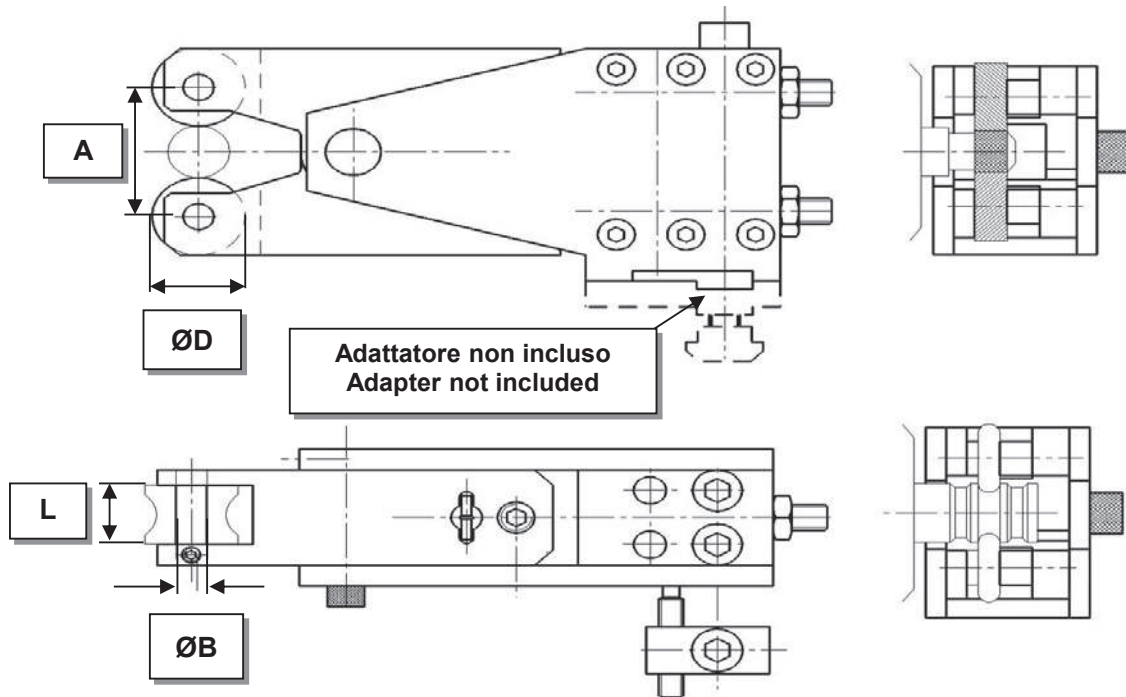
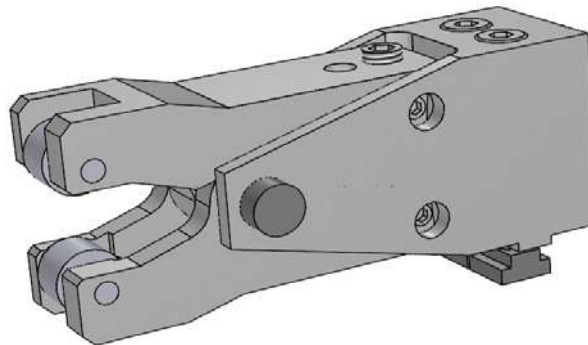

MODELLO E POSIZIONE MACHINE MODEL AND POS.	CODICE CODE	ADATTATORE ADAPTER	A MAX	ØD MAX	ØB	L
SAS16-AS14 pos.1-2-3-4	778500	-	24	15	4	11
SAS16-AS14 pos.4 con leva speciale con corsa 36mm <i>with special lever group for 36mm stroke</i>	770100-1	7711100	40	23	6	16
BS20 pos.1-2-3-4-5-6-7	778500	-	24	15	4	11
BS20 pos.5-6-7	770100-1	7711100	40	23	6	16

PORTARULLI DI SOSTEGNO ROLLER STEADIES

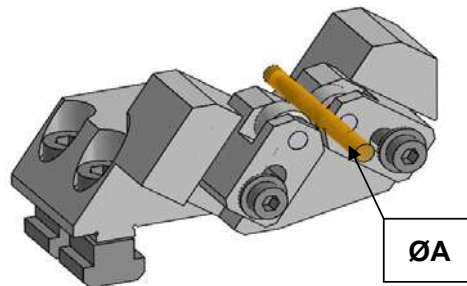

MACCHINA MACHINE	CODICE CODE	POS.	Ø A MAX	Ø A Min
BS 20	787000	1-2	16	4
BS 20	7810500	5-6-7	16	4
BS 20	7810600	3-4	16	4

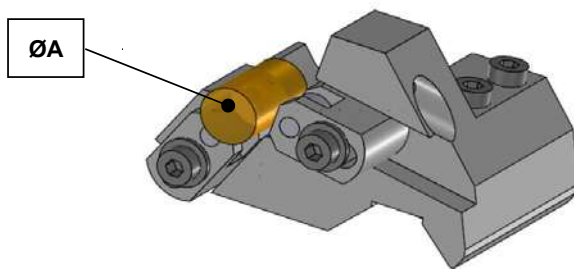

MACCHINA MACHINE	CODICE CODE	POS.	Ø A MAX	Ø A Min
SAS 16-AS14	788900	1-2	13	3,5
SAS 16-AS14	789000	3-4	13	3,5
SAS 16-AS14	789100	5	13	3,5

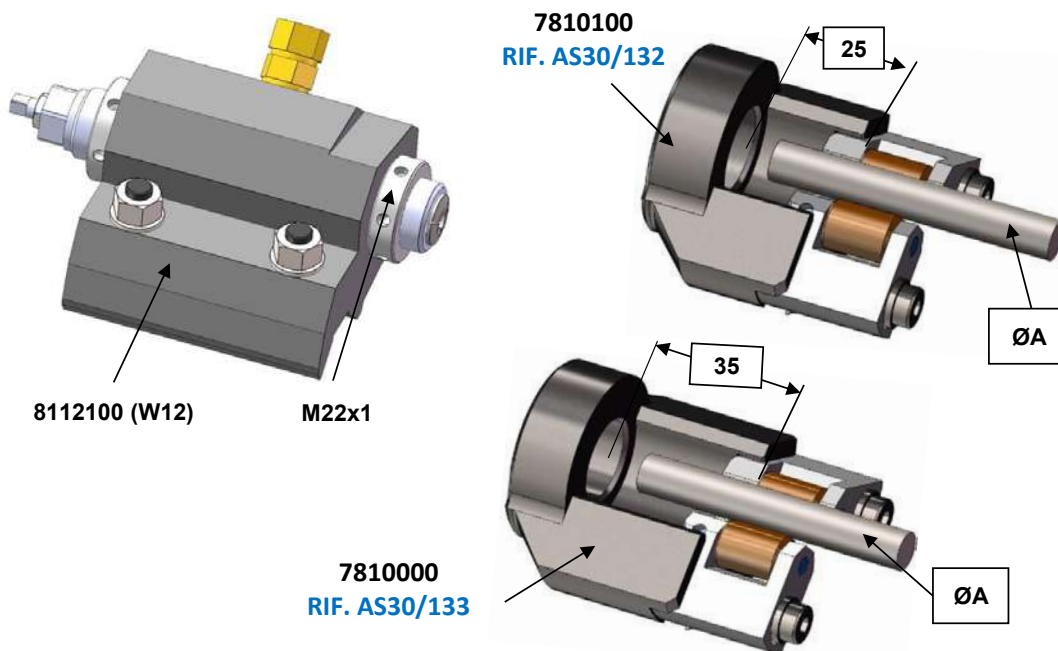

MACCHINA MACHINE	CODICE CODE	POS.	Ø A MAX	Ø A Min
SAS 16-AS14	7810000	1-2-3-4-5	12,5	3,5
SAS 16-AS14	7810100	1-2-3-4-5	12,5	3,5

SUPPORTI PER TESTA A RULLARE FETTE SUPPORTS FOR FETTE HEADS

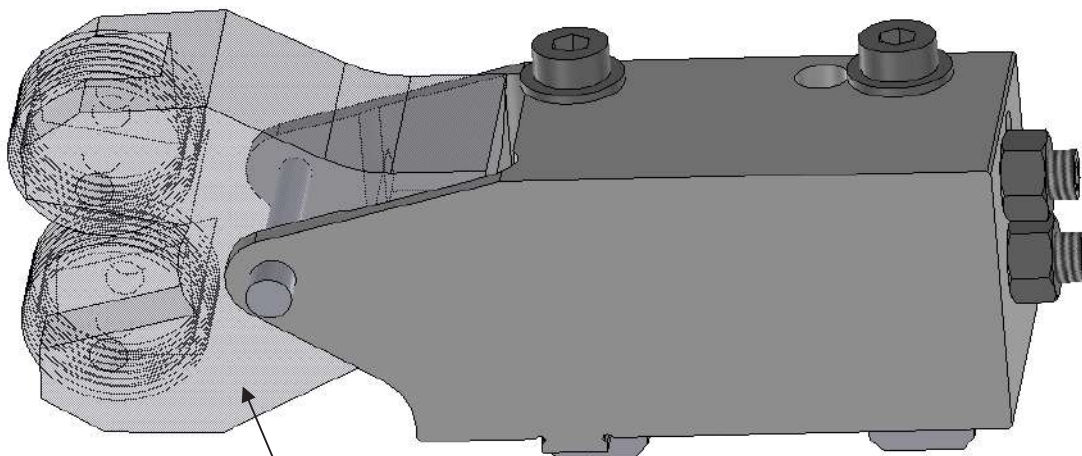

TESTA A RULLARE ESCLUSA
FETTE HEAD NOT INCLUDED

MACCHINA MACHINE	POS.	CODICE PART NUMBER	TESTA A RULLARE THREADING HEAD
SAS16-AS14	4-5	911700	FETTE T12
BS 20	5-6-7	912400	FETTE T18
BS 20	5-6-7	914200	FETTE T120F

Dispositivo per ricarica filiera a scatto
Device to re-load self opening threading head

931400
BS20

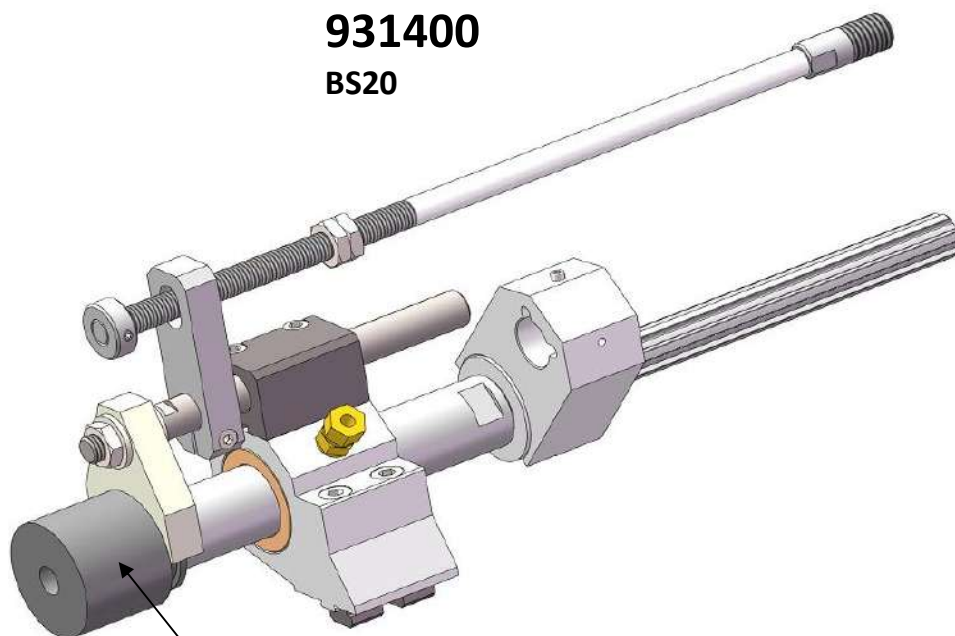

WAGNER ZR12 ESCLUSA
WAGNER ZR 12 NOT INCLUDED

931500
SAS16 - AS14

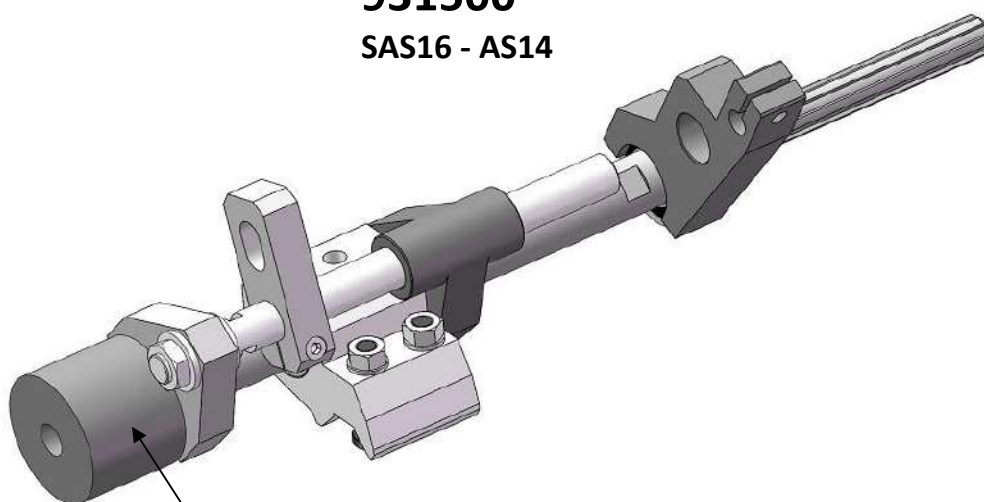

WAGNER ZR12 ESCLUSA
WAGNER ZR 12 NOT INCLUDED

PORTAPUNTA CON PORTAUTENSILE FRONTALE DRILL / TURNING TOOL HOLDER

981200

AS14 - SAS16 - BS20

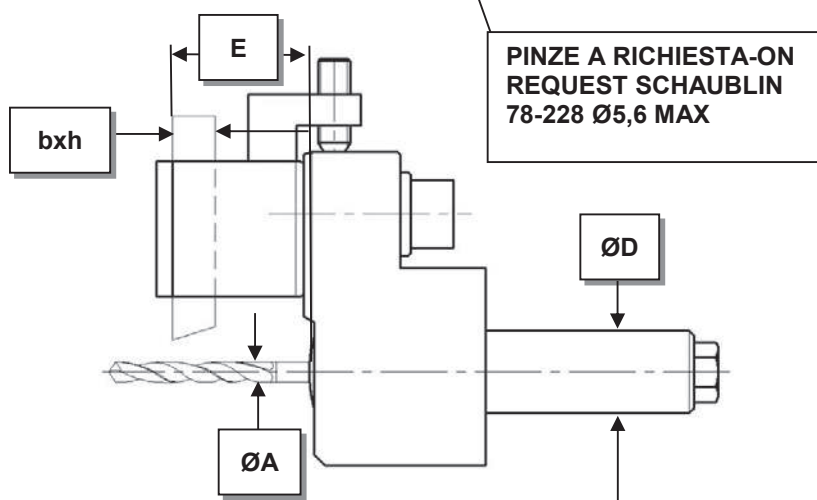
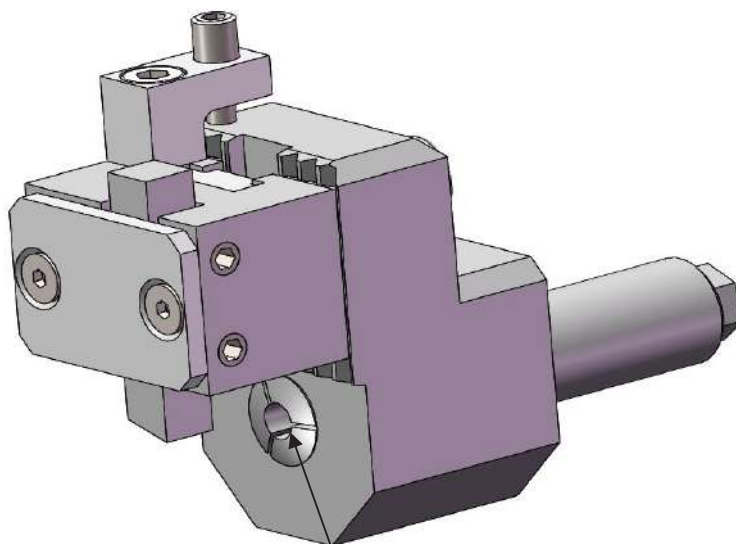

ØD	E	bxh	ØA	PINZE N° COLLETS N°
16	25,5	8x8	5,6	SCHAUBLIN 78- 228

PORTAPUNTA PER AS14 - SAS16 DRILL HOLDERS FOR AS14 - SAS16

PINZE ESCLUSE
COLLET EXCLUDED

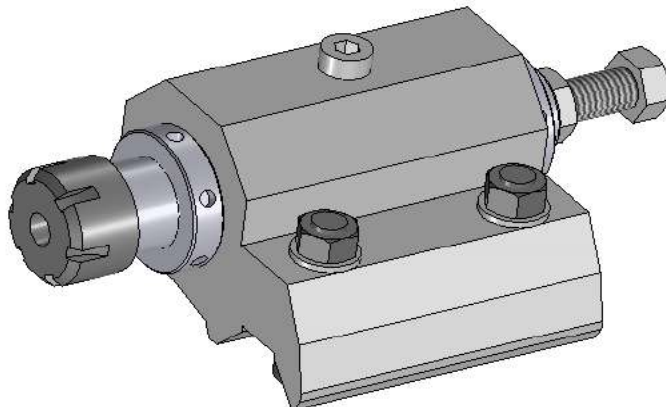

CODICE	TIPO DI PINZA	RIF. TORNOS
8111800	ER16 (FILETTO M22x1,5 TIPO REGO-FIX)	AS27/26
8111800-1	SCHAUBLIN ES16 61-16769 (FILETTO M22x1,25)	AS27/26
8113100	ER25	AS27/3-1

PINZE ESCLUSE
COLLET EXCLUDED

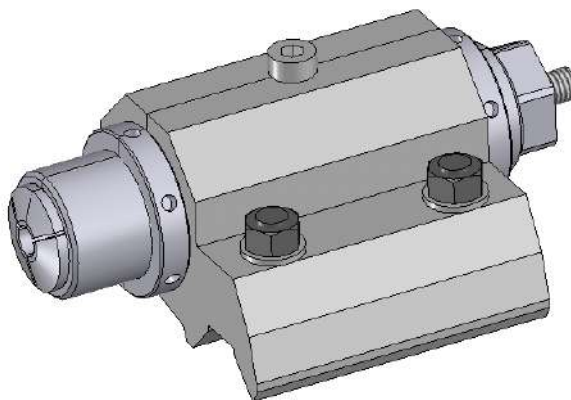

CODICE	TIPO DI PINZA	RIF. TORNOS
8112000	SCHAUBLIN W20	AS27/29
8112100	SCHAUBLIN W12	AS27/3

PORTAPUNTA PER AS14 - SAS16 DRILL HOLDERS FOR AS14 - SAS16

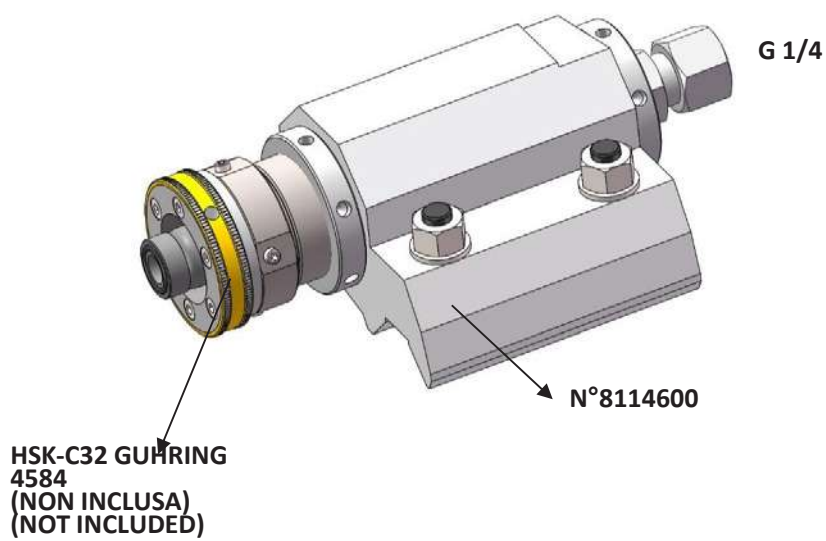
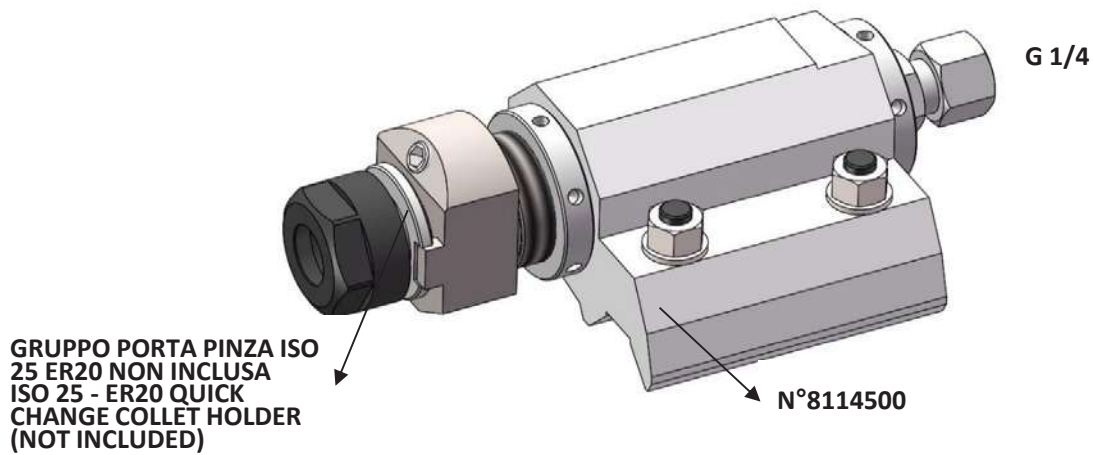

**PORTAPUNTA CON REFRIGERAZIONE
INTERNA PER BS20
*DRILL HOLDERS WITH COOLANT
THROUGH FOR BS20***

8113800

COD. TORNOS BS27/3

**PINZE ESCLUSE
COLLET EXCLUDED**

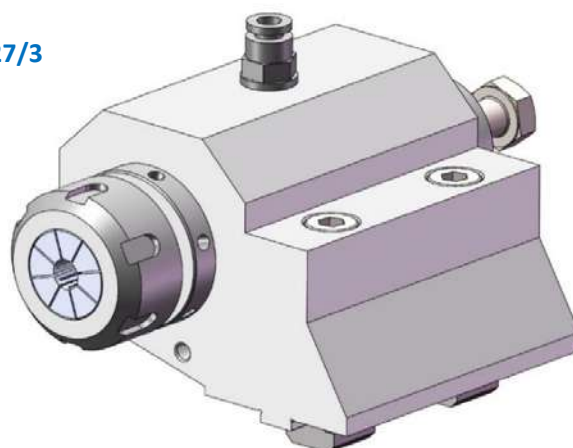

81115600

HSK C50

**ADATTATORE E PORTAUTENSILE HSK-C50 4584 ESCLUSO
ADAPTOR AND TOOL HOLDER HSK-C50 4584 EXCLUDED**

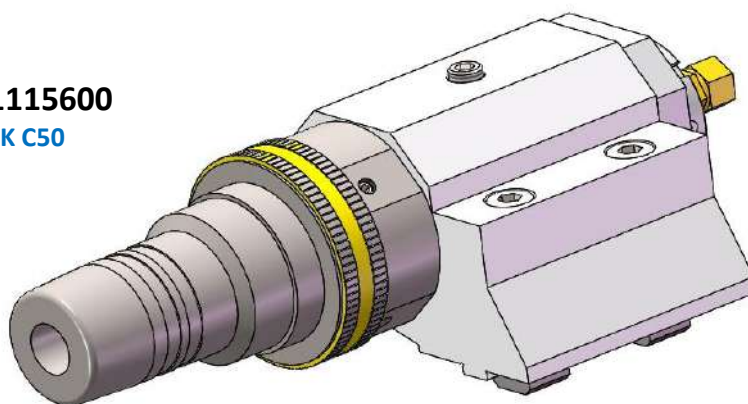

**PORTAPUNTA A COMANDO INDIPENDENTE E
REFRIGERAZIONE INTERNA PER AS14 - SAS16
INDEPENDENT DRILL HOLDERS COOLANT THROUGH
FOR AS14 - SAS16**

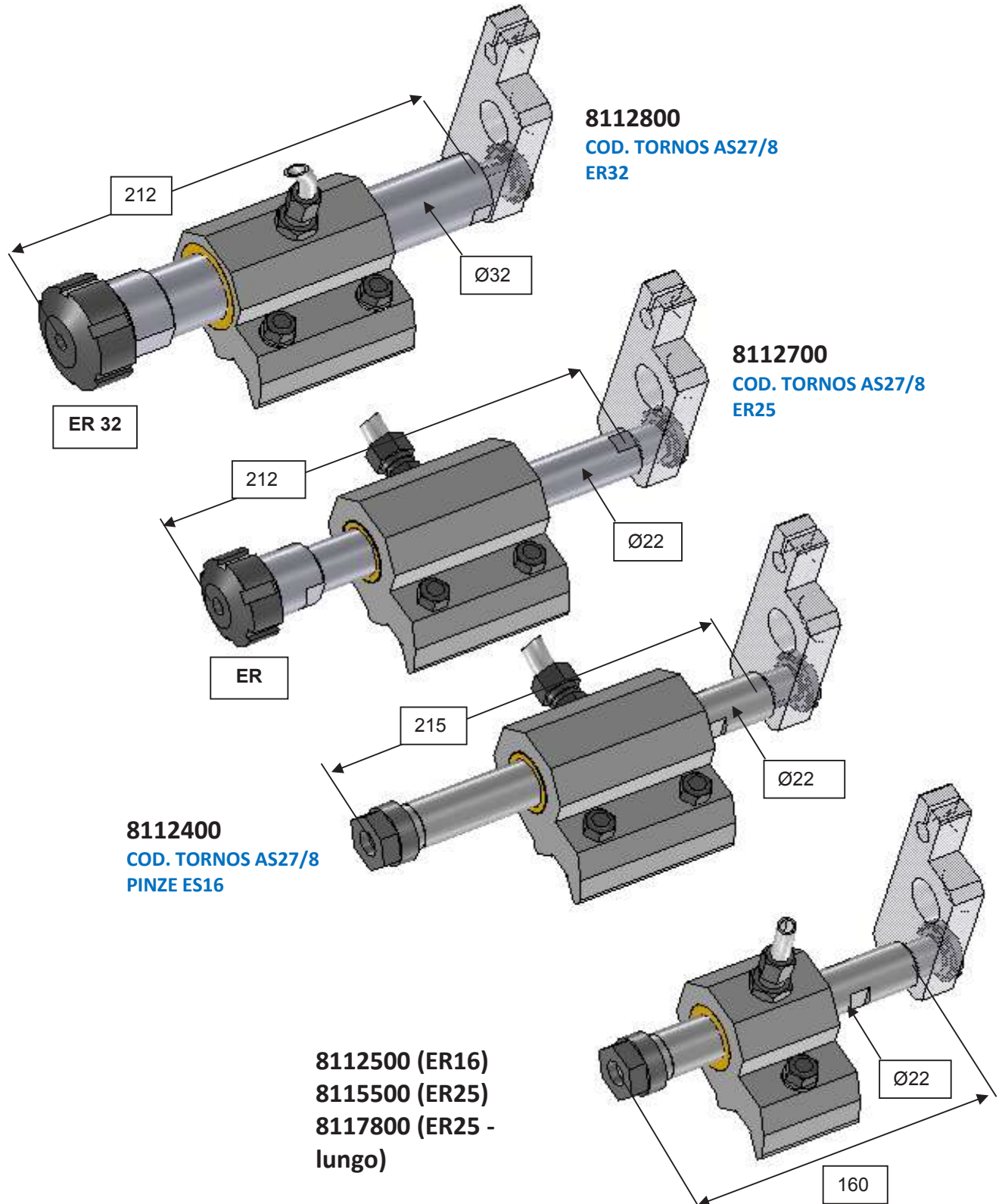

**PORTAPUNTA A COMANDO INDIPENDENTE
E REFRIGERAZIONE INTERNA PER BS20
INDEPENDENT DRILL HOLDER COOLANT THROUGH
FOR BS20**

8112600

COD. TORNOS AS27/8 ER32

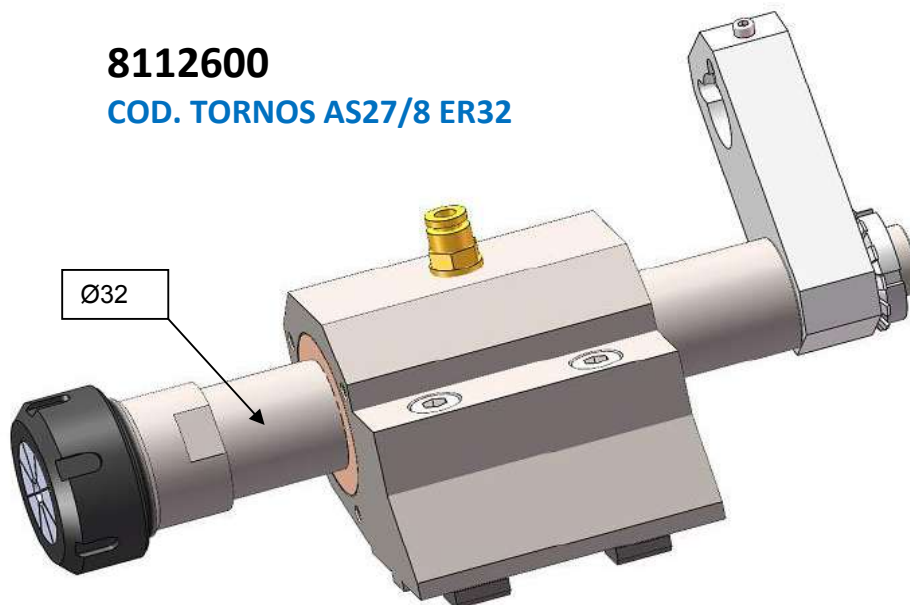

**PINZE ESCLUSE
COLLET EXCLUDED**

8115000

PINZE ER25

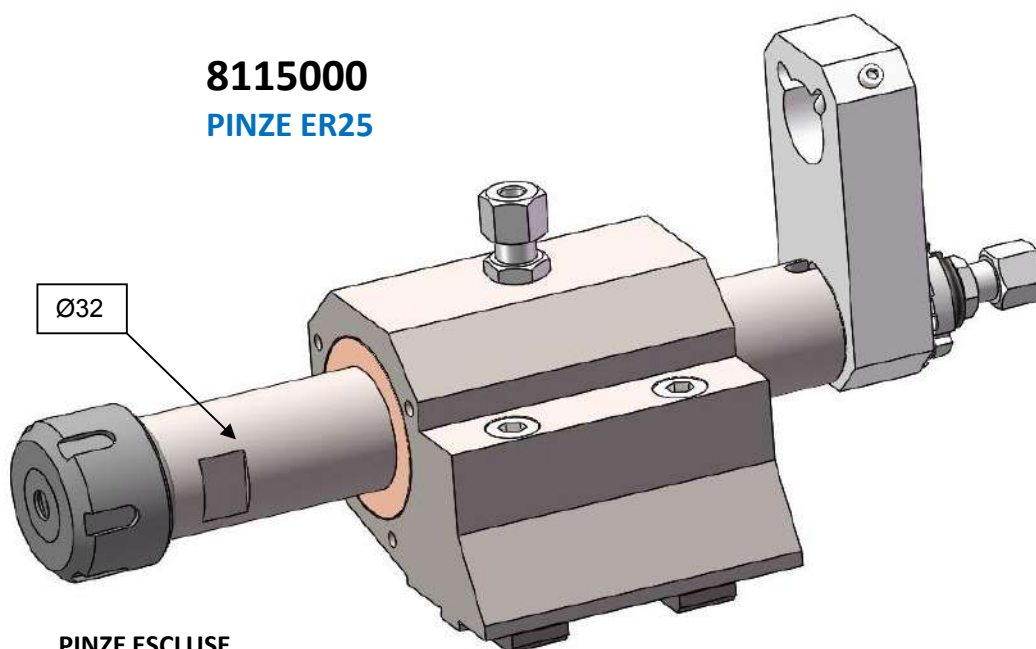

**PINZE ESCLUSE
COLLET EXCLUDED**

**MANDRINO CONTROROTANTE A COMANDO
INDIPENDENTE E REFRIGERAZIONE INTERNA PER BS20**

***INDEPENDENT HIGH SPEED DRILLING ATTACHMENT
WITH COOLANT THROUGH FOR BS20***

A398600-1

CON REFRIGERAZIONE AD ARIA
PINZE ER25

A398600-2

CON REFRIGERAZIONE STANDARD AD OLIO
PINZE ER25

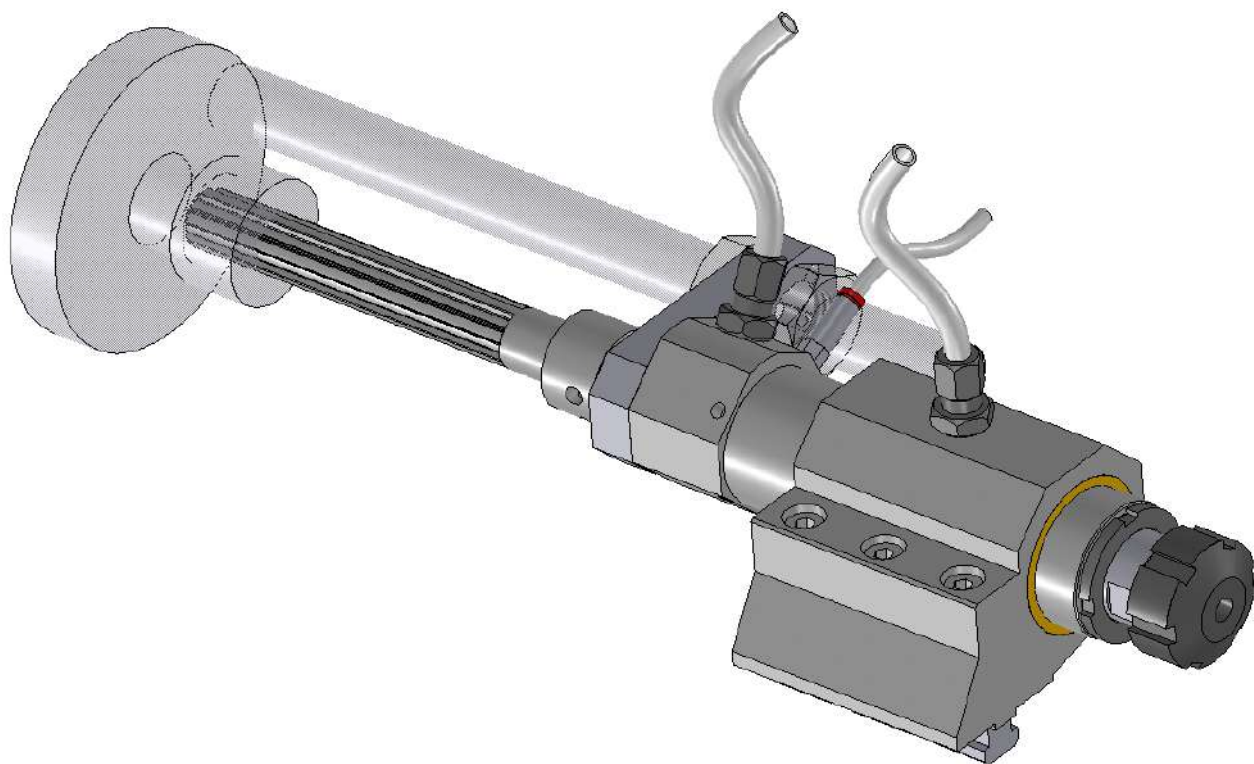

**MANDRINO CONTROROTANTE A COMANDO
INDIPENDENTE E REFRIGERAZIONE INTERNA
PER AS14-SAS16**

***INDEPENDENT HIGH SPEED DRILLING ATTACHMENT
WITH COOLANT THROUGH FOR AS14 - SAS16***

A399600

PINZE ER16 (GHIERE TIPO REGO FIX)

A399600-1

PINZE ES16 (GHIERE SCHAUBLIN 61-16769)
PER UTILIZZO CON PROLUNGHE

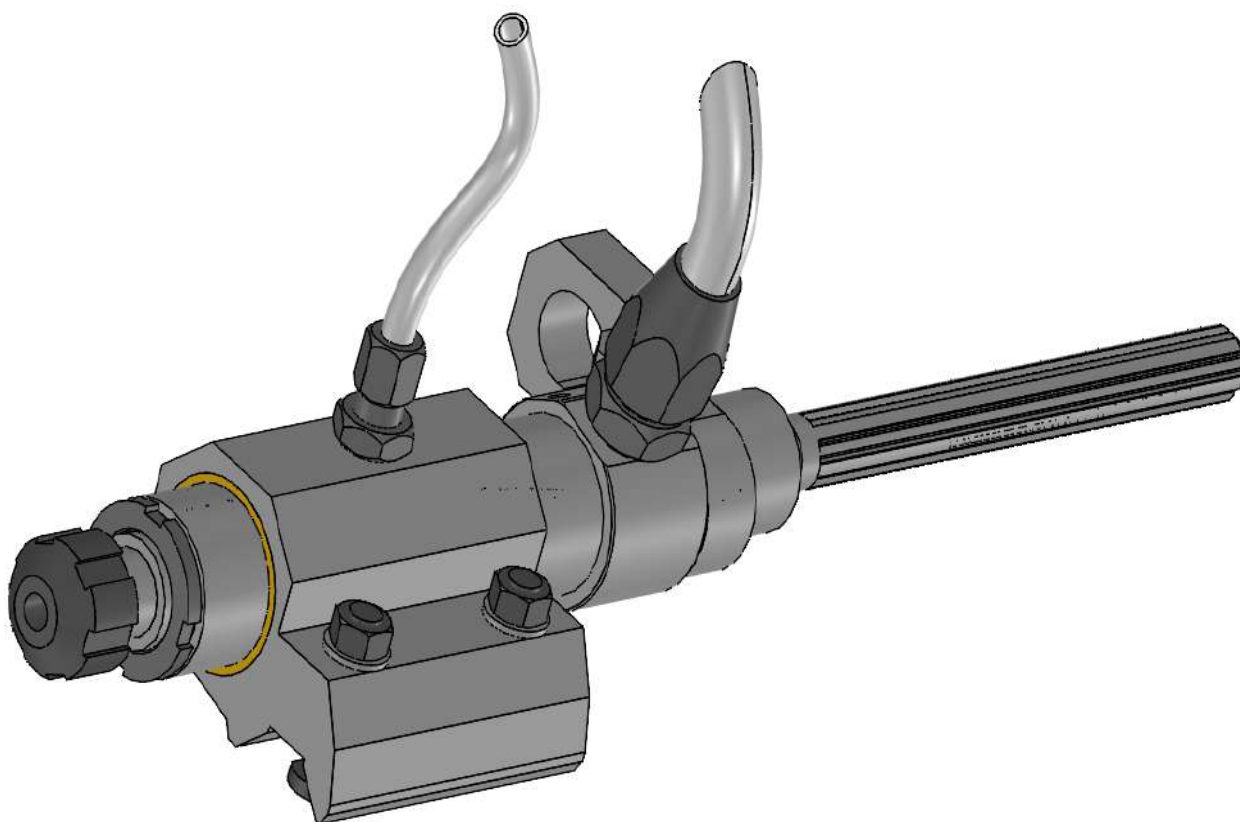

**MANDRINO CONTROROTANTE A COMANDO
INDIPENDENTE PER AS14-SAS16
INDEPENDENT HIGH SPEED DRILLING ATTACHMENT
FOR AS14 - SAS16**

A3914600

COD. TORNOS AS27/1

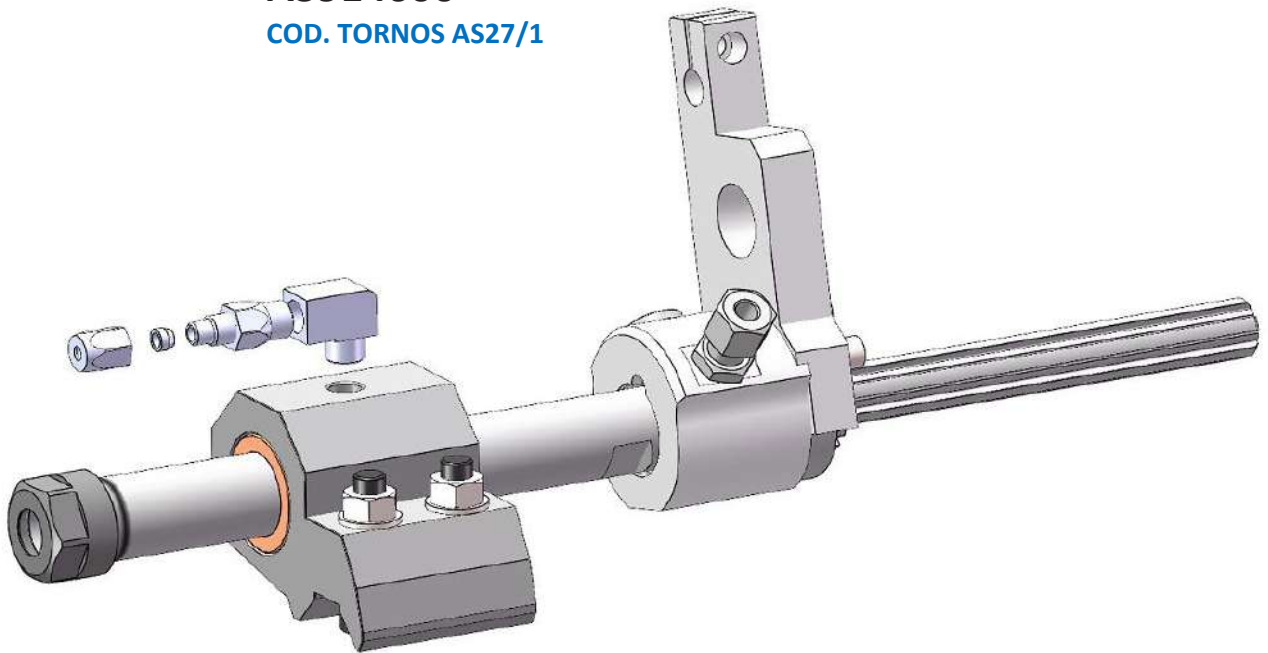

**FORCELLE DI COMANDO A RICHIESTA:
DRIVING FORKS ON REQUEST:**

A3914606
COD. TORNOS AS28127-1
POS. 4-5

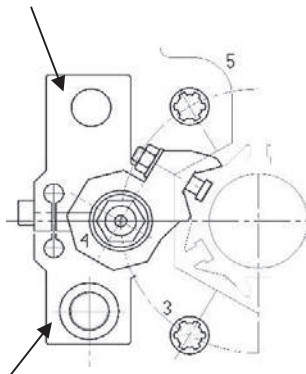

A3914605
COD. TORNOS AS28125-1
POS. 5

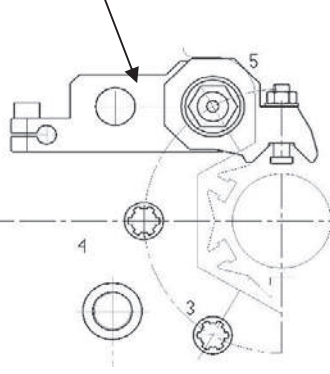

A3914607
COD. TORNOS AS28161-1
POS. 4-5 (DOPPIO)

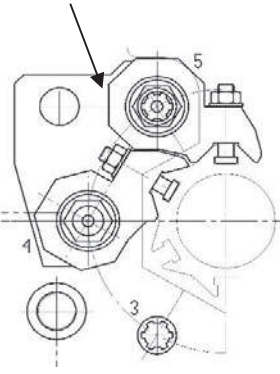

A3914609
COD. TORNOS AS28129-1
POS. 3-4

**MANDRINO CONTROROTANTE A COMANDO
INDIPENDENTE PER BS20
*INDEPENDENT HIGH SPEED DRILLING ATTACHMENT
FOR BS20***

A3915900

**COD. TORNOS BS27/1 ER25
PINZE ER25**

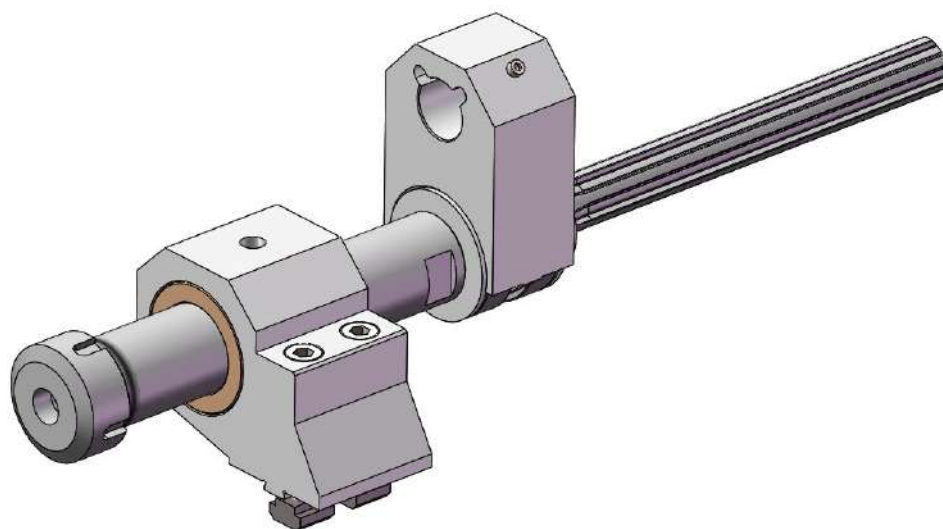

**MANDRINO CONTROROTANTE CON REFRIGERAZIONE
INTERNA PER AS14-SAS16
*HIGH SPEED DRILLING ATTACHMENT WITH COOLANT
THROUGH FOR AS14-SAS16***

A3916800
PINZE ER16 (GHIERE TIPO REGO FIX)

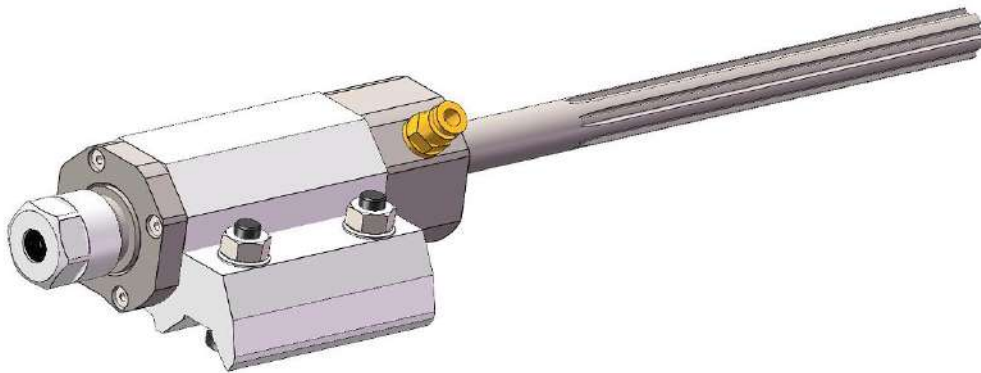

MANDRINO CONTROROTANTE HIGH SPEED DRILLING ATTACHMENT

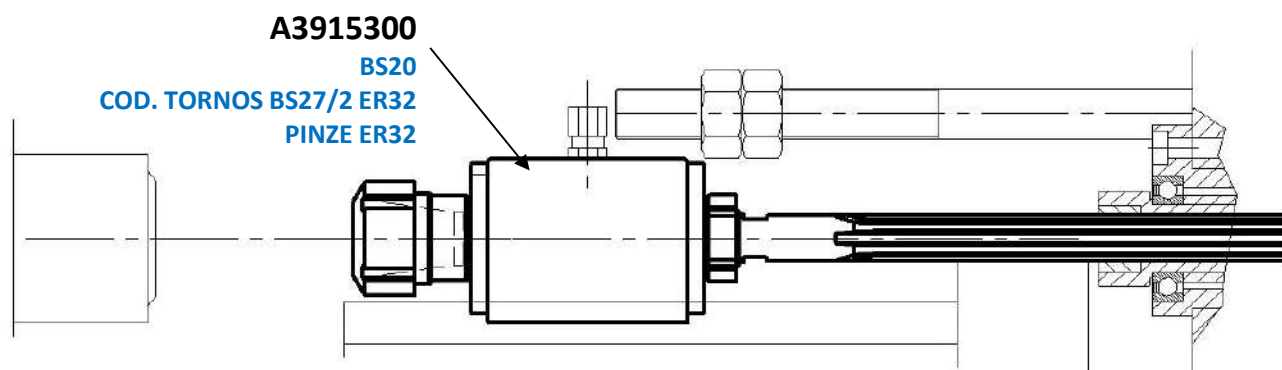
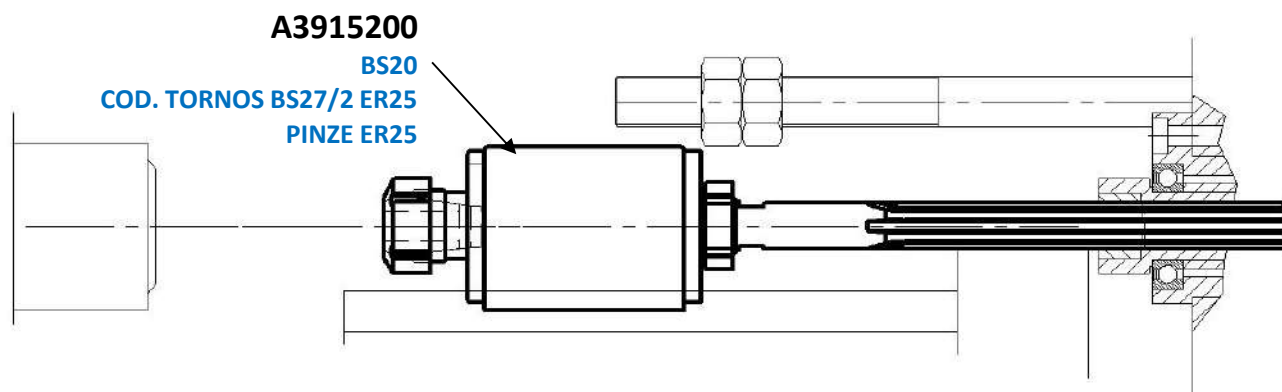
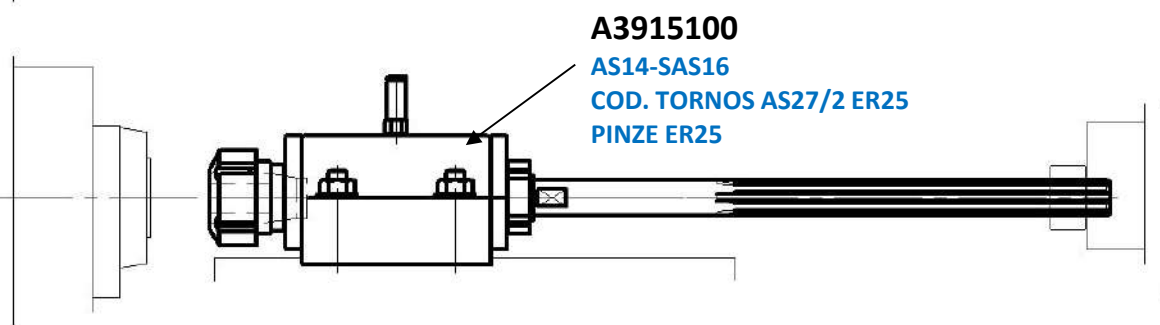
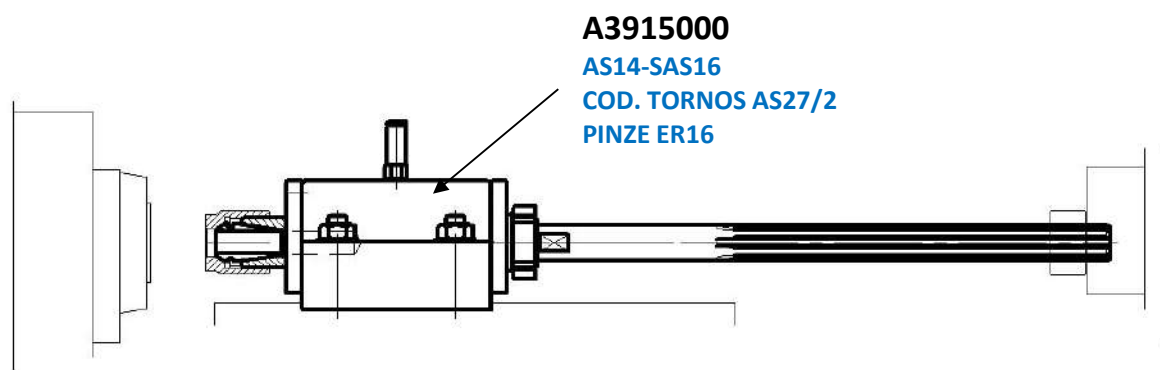

TESTINA A FORARE CON SERVOMOTORE

A436800 pos.1-2-5-6

A437100 pos.3-4-7

PINZE ERM20 (GHIERE TIPO REGO FIX)

BS 20 CON STOP MANDRINO

ADATTATORE N°A436900POS.1-2-5-6

ADATTATORE N°A437000 POS.3-4-7

A437100 pos.4

PINZE ERM20 (GHIERE TIPO REGO FIX)

SAS16 CON STOP MANDRINO

ADATTATORE N°A437000 POS.4

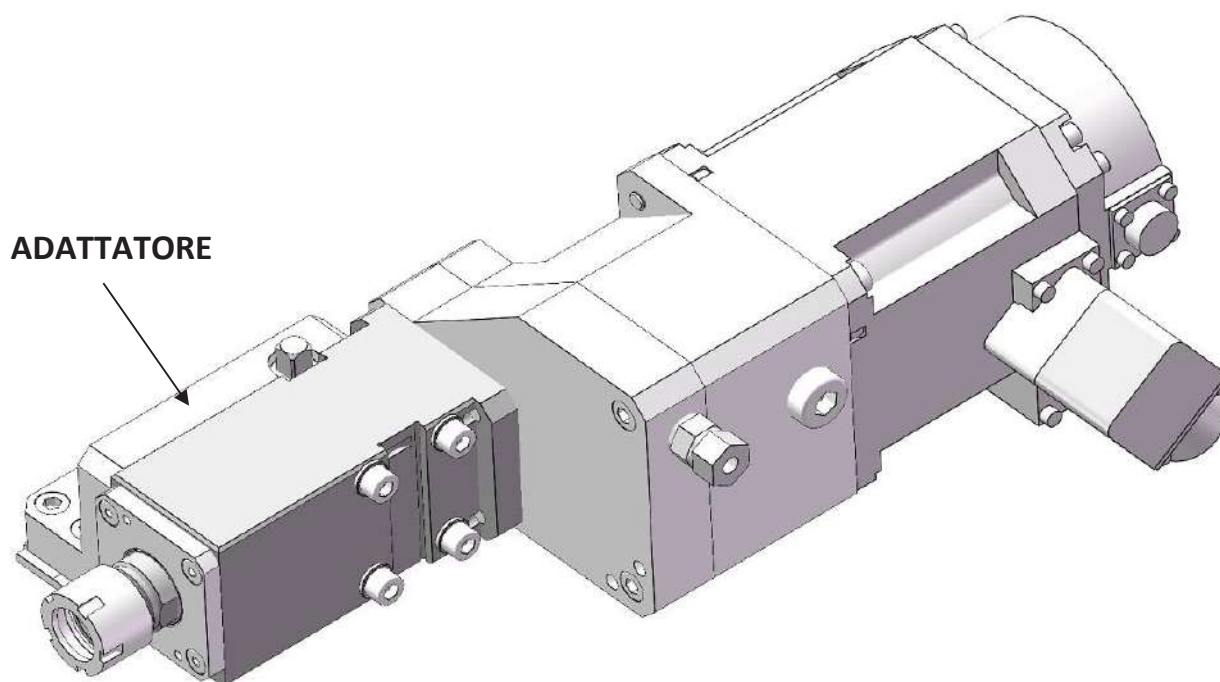

PROLUNGHE CON REFRIGERAZIONE INTERNA
SPINDLE EXTENSION COOLANT THROUGH

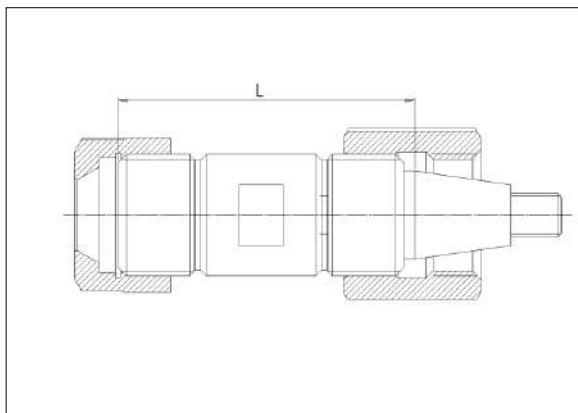

VERSIONE PINZE ER16

COD. 8114300 - L=54

COD. 8114400 - L=34

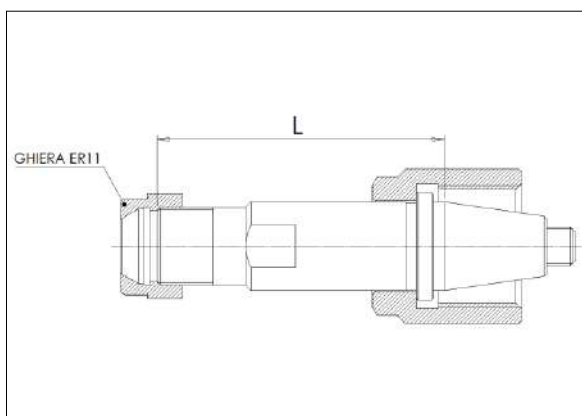

VERSIONE PINZE ER11

COD. 8116900 - L=52

COD. 8117000 - L=41

PRESA DI MOTO SAS16 DRIVING ASSEMBLY SAS16

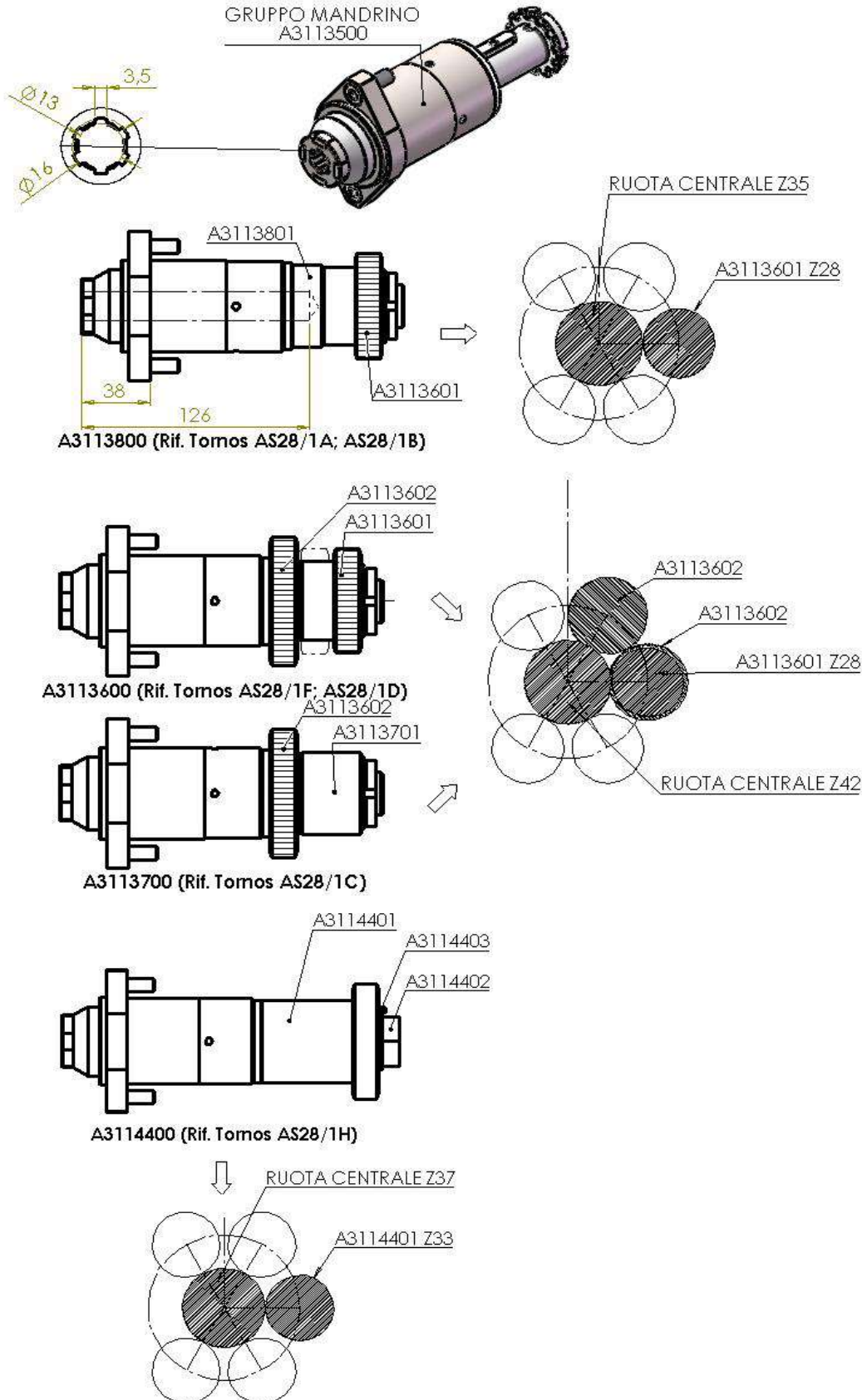

SLITTA SPECIALE RINFORZATA

AS14 - SAS16

SPECIAL REINFORCED SLIDE FOR AS14 - SAS16 POS.5

COMING SOON



Img Attachments S.r.l.
Viale 1° Maggio 16/F - 24030 Presezzo (Bergamo) - Tel. +39 035460246 Fax. +39 035614824
www.imgattachments.com